

ST. THOMAS & ELGIN AREA MUNICIPALITIES

SUPPLEMENTAL SPECIFICATIONS



Prepared by City of St. Thomas in partnership with:



CONTENTS

SUPPLEMENTAL SPECIFICATIONS - GENERAL..... 2

Part 1 AMMENDMENTS TO ONTARIO PROVINCIAL STANDARDS FOR ROADS AND PUBLIC WORKS GENERAL CONDITIONS OF CONTRACT (OPSS.MUNI 100) 2

SECTION GC 1.0 - INTERPRETATION 2

GC 1.04 Definitions..... 2

SECTION GC 2.0 - CONTRACT DOCUMENTS..... 2

GC 2.01 Reliance on Contract Documents..... 2

GC 2.02 Order of Precedence 3

SECTION GC 3.0 - ADMINISTRATION OF CONTRACT 4

GC 3.05 Layout 4

SECTION GC 5.0 - MATERIALS 4

GC 5.02 Quality of Materials..... 4

SECTION GC 6.0 - INSURANCE, PROTECTION AND DAMAGE 4

GC 6.01 Protection of Work, Persons and Property 4

GC 6.03.01 General..... 4

GC 6.03.02 General Liability Insurance 4

GC 6.05 Workplace Safety and Insurance Board 5

SECTION GC 7.0 CONTRACTOR'S RESPONSIBILITIES AND CONTROL OF WORK..... 5

GC 7.02 Monuments and Layout..... 5

GC 7.06 Maintaining Roads and Detours 5

GC 7.13 Obstructions 6

GC 7.14 Limitations of Operations..... 6

GC 7.16 Warranty..... 7

GC 7.18 Drainage..... 7

GC 8.0 MEASUREMENT AND PAYMENT 7

GC 8.01.02 Variation in Tender Quantities 7

GC 8.02.04.09 Interest for Late Payment 8

GC 8.02.09 Liquidated Damages 8

Part 2 SUPPLEMENTAL GENERAL CONDITIONS..... 9

2.1 OWNER AS CONSTRUCTOR..... 9

2.2 REMOVALS 9

2.3 RECYCLING, WASTE AND GREEN BIN COLLECTION..... 9

2.4 DRIVEWAY ACCESS AND MAINTENANCE MANAGEMENT 10

SUPPLEMENTAL SPECIFICATIONS - SEWERS..... 12

Part 1 AMMENDMENTS TO ONTARIO PROVINCIAL STANDARDS FOR ROADS AND PUBLIC WORKS 12

OPSS.MUNI 401 CONSTRUCTION SPECIFICATION FOR TRENCHING, BACKFILLING AND COMPACTION 12

401.05.01 Bedding and Embedment Material..... 12

401.05.02 Cover Material 12

401.05.04 Backfill Material..... 12

SUPPLEMENTAL SPECIFICATIONS

401.05.04.01 General.....	12
401.07 CONSTRUCTION.....	12
401.07.10 Backfilling and Compacting.....	12
401.07.10.03 Bedding.....	12
401.10 BASIS OF PAYMENT.....	13
401.10.01 Trenching, Backfilling, and Compacting.....	13
OPSS.MUNI 405 CONSTRUCTION SPECIFICATION FOR PIPE SUBDRAINS.....	13
405.05 MATERIALS.....	13
405.05.01 General.....	13
405.07 CONSTRUCTION.....	13
405.07.01 General.....	13
405.07.04 Geotextile.....	14
405.07.06 Laying Subdrain and Outlet Pipe.....	14
405.07.06.03 Connections to Drainage Structures.....	14
OPSS.MUNI 407 CONSTRUCTION SPECIFICATION FOR MAINTENANCE HOLE, CATCH BASIN, DITCH INLET AND VALVE CHAMBER INSTALLATION.....	14
407.05 MATERIALS.....	14
407.05.05 Adjustment Units.....	14
407.05.07 Frames With Covers or Grates.....	14
407.07 CONSTRUCTION.....	15
407.07.01 General.....	15
407.07.13 Installation of Inlet and Outlet Pipes Into Concrete Structures.....	15
407.07.14 Benching and Channeling.....	15
407.07.16 Installation of Frames with Grates or Covers.....	15
407.07.17 Installation of Aluminum Safety Platforms.....	16
407.10 BASIS OF PAYMENT.....	16
OPSS.MUNI 408 CONSTRUCTION SPECIFICATION FOR ADJUSTING OR REBUILDING MAINTENANCE HOLES, CATCH BASINS, DITCH INLETS, AND VALVE CHAMBERS.....	16
408.07 CONSTRUCTION.....	16
408.07.01 CONSTRUCTION.....	16
OPSS 409.MUNI CONSTRUCTION SPECIFICATION FOR CLOSED CIRCUIT TELEVISION INSPECTION OF PIPELINES.....	16
409.07 CONSTRUCTION.....	16
409.07.05 Final Documentation.....	16
409.07.05.01 Survey Reporting.....	16
OPSS.MUNI 410 CONSTRUCTION SPECIFICATIONS FOR PIPE SEWER INSTALLATION IN OPEN CUT.....	17
410.05 MATERIALS.....	17
410.05.01 PIPE MATERIALS.....	17
410.05.01.01 General.....	17
410.07 CONSTRUCTION.....	17
410.07.12 Pipe Installation.....	17
410.07.12.01 General.....	17
410.07.13 Service Connections.....	18
410.07.14 Marking and Recording Service Connections.....	20
410.07.16 Field Testing.....	20
410.07.16.01 General.....	20
410.07.16.06 Closed-Circuit Television (CCTV) Inspection.....	20
410.07.17 Cleaning and Flushing Pipe Sewers.....	20
OPSS 412.MUNI CONSTRUCTION SPECIFICATIONS FOR SEWAGE FORCEMAIN INSTALLATION IN OPEN CUT	
21	
412.05 MATERIALS.....	21

SUPPLEMENTAL SPECIFICATIONS

412.05.01 General.....	21
412.05.04 Polyvinyl Chloride Plastic Pressure Pipe Products	21
412.05.05 Polyethylene Plastic Pressure Pipe Products	21
412.07 CONSTRUCTION.....	21
412.07.16 Thrust Restraints	21
412.07.18 Cleaning and Flushing Force mains	22
OPSS.MUNI 421 CONSTRUCTION SPECIFICATION FOR PIPE CULVERT INSTALLATION IN OPEN CUT	22
421.05 MATERIALS	22
421.05.01 Pipe Materials.....	22
421.05.01.01 General.....	22
421.05.01.04 Polyethylene Pipe Products.....	22
421.07 CONSTRUCTION.....	22
421.07.12 Pipe Installation	22
421.07.12.01 General.....	22
OPSS.MUNI 510 CONSTRUCTION SPECIFICATION FOR REMOVAL.....	22
510.10 Basis of Payment.....	23
510.10.01 Removal of Item.....	23
Part 2 SUPPLEMENTAL SPECIFICATIONS FOR SEWERS	24
2.1 INVESTIGATE UNKNOWN SANITARY SERVICES.....	24
2.2 MANHOLE INSERTS	24
Part 3 SUPPLEMENTAL STANDARD DRAWINGS FOR SEWERS.....	25
S-01 TYPICAL SANITARY SEWER SERVICE CONNECTION	26
S-02 PRIVATE DRAIN CONNECTION CLEAN OUT	27
S-04 PRIVATE DRAIN CONNECTION VERTICAL RISER INSTALLATION.....	28
S-05 PRECAST 600mm x 840mm CURB INLET CATCHBASIN	29
S-06 CATCHBASIN INLET DETAILS	30
SUPPLEMENTAL SPECIFICATIONS - WATER	32
Part 1 AMMENDMENTS TO ONTARIO PROVINCIAL STANDARDS FOR ROADS AND PUBLIC WORKS	32
OPSS.MUNI 401 CONSTRUCTION SPECIFICATION FOR TRENCHING, BACKFILLING AND COMPACTION	32
401.05.01 Bedding and Embedment Material.....	32
401.05.02 Cover Material	32
401.05.04 Backfill Material.....	32
401.05.04.01 General.....	32
401.07 CONSTRUCTION.....	32
401.07.10 Backfilling and Compacting.....	32
401.07.10.03 Bedding.....	32
401.10 BASIS OF PAYMENT	32
401.10.01 Trenching, Backfilling, and Compacting.....	32
OPSS.MUNI 441 CONSTRUCTION SPECIFICATION FOR WATERMAIN INSTALLATION IN OPEN CUT	33
441.05 MATERIALS	33
441.05.01 General.....	33
441.05.02 Ductile Iron Pipe	33
441.05.04 Polyvinyl Chloride Pipe	33
441.05.04.01 General.....	33
441.05.04.02 Polyvinyl Chloride Pipe	33
441.05.04.03 Molecularly Oriented Polyvinyl Chloride Pipe (PVCO).....	34
441.05.05 Polyethylene Pipe	34
441.05.06 Steel Pipe	34

SUPPLEMENTAL SPECIFICATIONS

441.05.07 Copper Pipe.....	35
441.05.08 Composite Pipe	35
441.05.09 Valves.....	35
441.05.09.01 General.....	35
441.05.09.02 Service Line Valves	36
441.05.09.03 Gate Valves	36
441.05.10 Hydrants	36
441.05.12 Service Connection Fittings and Appurtenances	37
441.07 CONSTRUCTION.....	38
441.07.07 Transporting, Unloading, Storing, and Handling Pipe	38
441.07.14 Installation of Pipes.....	38
441.07.17 Change in Line and Grade.....	39
441.07.17.03 Polyvinyl Chloride Pressure Pipe - PVC and PVC0	39
441.07.18 Installation of Valves and Fittings	39
441.07.18.01 General.....	39
441.07.19 Installation of Hydrant Sets.....	39
441.07.20 Installation of Services Connections	40
441.07.21 Shutting Down or Charging Mains	40
441.07.22 Connections to Existing Watermains	40
441.07.23 Thrust Restraints	41
441.07.24 Hydrostatic Testing.....	42
441.07.24.01 General.....	42
441.07.25 Flushing and Disinfecting Watermains.....	42
441.07.27 Management of Excess Material.....	44
OPSS.MUNI 493 CONSTRUCTION SPECIFICATION FOR TEMPORARY POTABLE WATER SUPPLY SERVICES.....	45
493.04 Design and Submission Requirements.....	45
493.04.01 Submission Requirements.....	45
OPSS.MUNI 510 CONSTRUCTION SPECIFICATION FOR REMOVAL.....	45
510.10 Basis of Payment.....	45
510.10.01 Removal of Item.....	45
Part 2 SUPPLEMENTAL SPECIFICATIONS FOR WATER.....	46
2.1 Materials.....	46
2.2 Tapping Sleeves and Valves	46
2.3 Corrosion Protection.....	46
2.4 Thermal Insulation.....	47
2.5 Tracer Wire.....	47
2.6 Drinking Water Quality Management System (DWQMS)	48
Part 3 STANDARD DRAWINGS FOR WATER	49
W-01 Thrust Restraint for Watermain up to and Including 300mm ø	50
W-02 Typical Offset Watermain	51
W-03 Fire Hydrant and Valve Box Detail	52
W-04 Watermain Service Installation.....	53
W-06 Standard 50mmø Blow-off	54
W-07 Magnesium Anode Installation	55
W-09 Tracer Wire Connection	56
W-13 Typical Turbine Water Meter Installation for 75mmø to 200mmø.....	57
W-17 Water Sampling Station Detail	58
W-18 Bottom Board for 25mm Water Services.....	59
W-20 Magnesium Anode Configuration for Various Metallic Fittings	60
SUPPLEMENTAL SPECIFICATIONS - ROADS	62

SUPPLEMENTAL SPECIFICATIONS

Part 1 AMMENDMENTS TO ONTARIO PROVINCIAL STANDARDS FOR ROADS AND PUBLIC WORKS 62

OPSS 102 GENERAL SPECIFICATION FOR MATERIAL WEIGHING..... 62

 102.07 CONSTRUCTION – WEIGHING 62

 102.07.01.01 Mass Measurement 62

OPSS.MUNI 180 GENERAL SPECIFICATION FOR THE MANAGEMENT OF EXCESS MATERIAL..... 62

 180.01 SCOPE 62

 180.07.01 Conditions on Management of Excess Material – General 62

OPSS.MUNI 201 CONSTRUCTION SPECIFICATION FOR CLEARING, CLOSE CUT CLEARING, GRUBBING, AND REMOVAL OF SURFACE AND PILED BOULDERS 63

 201.07 CONSTRUCTION..... 63

 201.07.01 General..... 63

OPSS.MUNI 206 CONSTRUCTION SPECIFICATION FOR GRADING..... 63

 206.07 CONSTRUCTION..... 63

 206.07.01.04 Tolerances - General 63

 206.07.03.01.03 Excavation Below Subgrade 63

OPSS.MUNI 310 CONSTRUCTION SPECIFICATION FOR HOT MIX ASPHALT 63

 310.07 CONSTRUCTION..... 63

 310.07.05.02 Hot Mix Asphalt..... 63

 310.07.05.02.01 General 63

 310.07.05.02.04 Cores 64

 310.07.08 Widening and Irregular Sections 64

 310.07.11 Longitudinal and Transverse Joints 64

 310.07.11.01 General 64

 310.07.14 Surface Appearance 64

 310.08 QUALITY ASSURANCE 64

 310.08.01 General..... 64

 310.10 BASIS OF PAYMENT..... 65

 310.10.01 - Items..... 65

OPSS.MUNI 331 CONSTRUCTION SPECIFICATION FOR FULL DEPTH RECLAMATION WITH EXPANDED ASPHALT STABILIZATION 65

 331.10 BASIS OF PAYMENT..... 65

 331.10.01 Full-Depth Reclamation with Expanded Asphalt Stabilization - Item..... 65

OPSS.MUNI 333 CONSTRUCTION SPECIFICATION FOR COLD IN-PLACE RECYCLING 65

 333.10 BASIS OF PAYMENT..... 65

 333.10.01 Cold In-Place Recycled Mix - Item..... 65

OPSS 350 CONSTRUCTION SPECIFICATION FOR CONCRETE PAVEMENT AND CONCRETE BASE..... 66

 350.05 MATERIALS 66

 350.05.01 Concrete 66

 350.07 CONSTRUCTION..... 66

 350.07.02 Joints 66

 350.07.02.01 General..... 66

 350.07.02.04 Position and Alignment Tolerances 66

 350.07.02.04.02 Joints 66

 350.07.03.02 Finishing 67

 350.07.05 Joint Sealing 67

 350.07.08 Sampling and/or Testing 67

 350.07.08.01 Slump and Air Content..... 67

 350.07.08.02 Coring 67

SUPPLEMENTAL SPECIFICATIONS

350.07.08.05 Transportation of Cores	67
350.08 QUALITY ASSURANCE	68
350.08.01 Acceptance Criteria for Strength and Thickness	68
350.08.01.03 Lot Size.....	68
350.08.01.03.01 Compressive Strength and Thickness	68
350.08.01.05 Removal of Unacceptable Concrete	69
350.09 MEASUREMENT FOR PAYMENT	69
350.09.01 Actual Measurement	69
350.09.01.01 Concrete Pavement	69
350.10 BASIS OF PAYMENT	69
350.10.01 Concrete Pavement - Item	69
350.10.01.01 Compressive Strength and Slab Thickness	69
OPSS.MUNI 351 CONSTRUCTION SPECIFICATION FOR CONCRETE SIDEWALK.....	70
351.05 MATERIALS	70
351.05.06 Tactile Walking Surface Indicator Plates	70
351.07 CONSTRUCTION.....	70
351.07.02.02 Granular Base.....	70
351.07.06 Utility Adjustment	70
351.07.09 Tactile Walking Surface Indicator Plate Installation	70
351.07.11 Joints	71
351.07.11.04 Expansion Joints.....	71
351.07.17 Tactile Walking Surface Tolerances	71
351.10.02 Tactile Walking Surface Indicators for Concrete Sidewalk Ramps – Item	71
OPSS 353 CONSTRUCTION SPECIFICATION FOR CONCRETE CURB AND GUTTER SYSTEMS	71
353.07 CONSTRUCTION.....	71
353.07.02 Foundation and Backfill	71
OPSS.MUNI 501 CONSTRUCTION SPECIFICATION FOR COMPACTING	72
501.07 CONSTRUCTION.....	72
501.07.01 General.....	72
OPSS.MUNI 706 CONSTRUCTION SPECIFICATION FOR TRAFFIC CONTROL SIGNING.....	72
706.07 Construction.....	72
706.07.01.02 Existing Small Signs	72
OPSS.MUNI 710 CONSTRUCTION SPECIFICATION FOR PAVEMENT MARKING.....	72
710.02 REFERENCES	72
710.04 DESIGN AND SUBMISSION	73
710.04.01 General.....	73
710.05 MATERIALS	73
710.05.03 Thermoplastic Pavement Marking Materials	73
710.05.04 Field Reacted Polymeric Pavement Marking Materials.....	73
710.05.05 Preformed Plastic Pavement Marking Tape.....	73
710.07 CONSTRUCTION.....	73
710.07.03 Pavement Marking Obliterating.....	73
710.07.07 Permanent Pavement Marking	74
710.09 MEASUREMENT FOR PAYMENT	74
710.09.01 Actual Measurement	74
710.09.01.01 Pavement Marking.....	74
OPSS.MUNI 510 CONSTRUCTION SPECIFICATION FOR REMOVAL.....	74
510.10 Basis of Payment.....	74
510.10.01 Removal of Item.....	74
OPSS.MUNI 1010 MATERIAL SPECIFICATION FOR AGGREGATES – BASE, SUBBASE, SELECT SUBGRADE, AND BACKFILL MATERIAL	74

SUPPLEMENTAL SPECIFICATIONS

1010.05 Materials	74
1010.05.03.02 Granular B Type II	74
Part 2 SUPPLEMENTAL SPECIFICATIONS FOR ROADS	75
2.1 Painting Edge of Concrete Curb and Gutter Reveal	75
2.2 Asphalt Ramps	75
Part 3 SUPPLEMENTAL STANDARD DRAWINGS FOR ROADS	76
R-01 Driveway Apron - Typical Section	77
R-11 Removable Bollard & Trail Head Detail	78
SUPPLEMENTAL SPECIFICATIONS - LANDSCAPING	80
Part 1 AMENDMENTS TO ONTARIO PROVINCIAL STANDARDS FOR ROADS AND PUBLIC WORKS	80
OPSS.MUNI 801 CONSTRUCTION SPECIFICATION FOR THE PROTECTION OF TREES	80
801.03 DEFINITIONS	80
801.07 CONSTRUCTION	81
801.07.01 Operational Constraints	81
801.07.02 Barrier for Tree Protection	81
801.07.03 Tree Repair	82
OPSS.MUNI 802 CONSTRUCTION SPECIFICATION FOR TOPSOIL	82
802.05 MATERIALS	82
802.07 CONSTRUCTION	83
802.07.02 Preparation for Topsoil	83
802.07.03 Placement of Topsoil	83
802.09 MEASUREMENT FOR PAYMENT	83
802.09.01.01 Topsoil from Stockpiles	83
802.09.01.02 Topsoil, Imported	83
OPSS.MUNI 803 CONSTRUCTION SPECIFICATION FOR SODDING	83
803.07 CONSTRUCTION	83
803.07.04 Placement of Sod	83
803.07.05 Maintenance of Completed Sodding	83
803.08 QUALITY ASSURANCE	84
803.08.01 Performance Measure	84
803.08.02 Acceptance	84
OPSS.MUNI 804 CONSTRUCTION SPECIFICATION FOR SEED AND COVER	84
804.05 MATERIALS	84
804.05.01 Seed	84
804.05.01.04 Permanent Seed Mixes	84
Part 2 SUPPLEMENTAL SPECIFICATIONS FOR LANDSCAPING	85
2.1 Tree Removals	85
2.2 Tree Planting	85
2.3 Tree and Shrub Relocation	87
2.4 Penalty for Tree Damage	88
Part 3 SUPPLEMENTAL STANDARD DRAWINGS FOR LANDSCAPING	89
L-01 Tree Planting Detail	90
SUPPLEMENTAL SPECIFICATIONS – TRAFFIC SIGNALS	92
Part 1 AMENDMENTS TO ONTARIO PROVINCIAL STANDARDS FOR ROADS AND PUBLIC WORKS	92

SUPPLEMENTAL SPECIFICATIONS

OPSS.MUNI 106 GENERAL SPECIFICATION FOR ELECTRICAL WORK.....	92
106.04 Design and Submission Requirements.....	92
106.05 Materials.....	92
106.07.01.02 Contractor’s Workers.....	93
106.07.02 Work to be Inspected by Electrical Safety Authority.....	93
106.07.04 Traffic Signal Systems.....	94
106.07.06 Temporary Electrical Work.....	94
106.07.07 Layout of Electrical Equipment.....	95
106.07.08 Adjustment of Electrical Equipment.....	95
106.07.10 Quality Control.....	95
OPSS.MUNI 602 CONSTRUCTION SPECIFICATION FOR INSTALLATIONS OF ELECTRICAL CHAMBERS.....	96
602.07.11.02 Electrical Handholes.....	96
602.07.13 Design and Submission Requirements.....	97
OPSS.MUNI 603 CONSTRUCTION SPECIFICATION FOR INSTALLATIONS OF DUCTS.....	97
603.05.08 Ducts and Fittings.....	97
603.07.15 Termination.....	98
603.07.16 Backfilling.....	98
603.10.16 Basis of Payment.....	99
OPSS.MUNI 609 CONSTRUCTION SPECIFICATION FOR GROUNDING.....	99
609.07 Construction.....	99
OPSS.MUNI 610 CONSTRUCTION SPECIFICATION FOR REMOVAL OF ELECTRICAL EQUIPMENT AND MATERIALS.....	100
610.07 Construction.....	100
OPSS.MUNI 614 CONSTRUCTION SPECIFICATION FOR INSTALLATION OF POWER SUPPLY EQUIPMENT ...	101
614.05 Materials.....	101
614.07 Construction.....	102
OPSS.MUNI 615 CONSTRUCTION SPECIFICATION FOR ERECTION OF POLES.....	102
615.05 Materials.....	102
OPSS.MUNI 616 CONSTRUCTION SPECIFICATION FOR FOOTINGS AND PADS FOR ELECTRICAL EQUIPMENT	
103	
616.08 Quality Assurance.....	103
OPSS.MUNI 620 CONSTRUCTION SPECIFICATION FOR TRAFFIC SIGNAL EQUIPMENT AND ELECTRICAL TRAFFIC CONTROL DEVICES.....	103
620.02 Definitions.....	103
620.07 Construction.....	104
OPSS.MUNI 2461 MATERIAL SPECIFICATION FOR SIGNAL HEADS.....	106
2461.05 Materials.....	106
Part 2 SUPPLEMENTAL SPECIFICATIONS FOR TRAFFIC SIGNALS.....	107
2.1 Traffic Signal Wiring.....	107
2.2 Mounting Equipment.....	108
2.3 Maintenance of Traffic.....	109
Part 3 TRAFFIC SIGNAL ACTIVATION CHECKLIST.....	110
Part 4 TRAFFIC CONTROLLER TAG LABELLING.....	113



SUPPLEMENTAL SPECIFICATIONS GENERAL

SUPPLEMENTAL SPECIFICATIONS - GENERAL

Part 1 AMMENDMENTS TO ONTARIO PROVINCIAL STANDARDS FOR ROADS AND PUBLIC WORKS GENERAL CONDITIONS OF CONTRACT (OPSS.MUNI 100)

The Ontario Provincial Standards for Roads and Public Works in effect immediately prior to the call for Tenders for this Contract shall apply for the duration of the Contract.

SECTION GC 1.0 - INTERPRETATION

GC 1.04 Definitions

Add the following definitions:

“Calendar Day”

shall mean each and every full 24 hour period from midnight to midnight without exception.

Amend the definition of "Contract Documents" as follows:

"Contract Documents"

mean the executed Agreement between the Owner and the Contractor, the Tender, the Ontario Provincial Standards for Roads and Public Work, Volumes 1 - 4 inclusive and Volumes 7 and 8, Supplemental Specifications, Special Provisions, Contract Drawings, addenda incorporated in a Contract Document before the execution of the Agreement, such other documents as may be listed in the Agreement, and subsequent amendments to the Contract Document made pursuant to the provisions of the Agreement.

SECTION GC 2.0 - CONTRACT DOCUMENTS

GC 2.01 Reliance on Contract Documents

Delete paragraph a) of subsection GC 2.01.01 and replace with the following:

- a) The location of all mainline underground Utilities that may affect the Work shall be shown to a tolerance of:
 - i. 1 m horizontal, and
 - ii. 1 m vertical

GC 2.02 Order of Precedence

Delete Order of Precedence a) to j) as set out in paragraph .01 subsection GC 2.02 and replace with the following:

- a) Agreement
- b) Addenda
- c) Special Provisions
- d) Contract Drawings
- e) Supplemental Specifications
- f) Information for Tenderers
- g) Form of Tender
- h) Ontario Provincial Standards for Roads and Public Works, Volumes 1 – 4 inclusive and Volumes 7 and 8
- i) Ontario Traffic Manual
- j) Working Drawings

SECTION GC 3.0 - ADMINISTRATION OF CONTRACT**GC 3.05 Layout**

Delete paragraph .02 of subsection GC 3.05.

SECTION GC 5.0 - MATERIALS**GC 5.02 Quality of Materials**

Amend paragraph .03 of subsection GC 5.02 by adding the following:

The Contractor shall supply to the contract administrator such materials, labour and other assistance as may be required to procure, package and ship all test samples.

SECTION GC 6.0 - INSURANCE, PROTECTION AND DAMAGE**GC 6.01 Protection of Work, Persons and Property**

Delete paragraph d) of subsection GC 6.01.04

GC 6.03.01 General

Delete paragraph .01 of subsection GC 6.03.01 and replace with the following:

.01 Without restricting the generality of subsection GC 6.02, Indemnification, the Contractor shall provide, maintain and pay for the insurance coverages listed in the General Condition under clauses GC 6.03.02, GC 6.03.03 and GC 6.03.06. In all cases where the work directly involves use of owned or non-owned watercraft and/or aircraft or construction or material alteration of a building or other structure or where installation of boilers and/or pressure vessels forms part of the work, the Contractor shall provide the applicable insurance coverage described in subsection GC 6.03.04 and GC 6.03.05.01 and .02.

GC 6.03.02 General Liability Insurance

Add subsection .08 and .09 to subsection GC 6.03.02 as follows:

.08 The IBC Form 2100 as required shall also contain the following policy endorsements:

- Cross liability,
- Contractual liability,
- Products and completed operations, and
- Employer's liability

.09 The policies provided shall not contain any exclusions or limitations in respect of shoring, underpinning, raising or demolition of any building or structure, pile driving, caisson work, collapse of any structure or subsidence of any property structure or land from any cause.

GC 6.05 Workplace Safety and Insurance Board

Amend subsection GC 6.05.01 by the addition of the following:

- e) Prior to issue of all Payment Certificates

SECTION GC 7.0 CONTRACTOR'S RESPONSIBILITIES AND CONTROL OF WORK

GC 7.02 Monuments and Layout

Delete paragraph .06 of subsection GC 7.02 and replace with the following:

- .06 At no extra cost to the Owner, the Contractor shall provide the Contract Administrator with such assistance, labour, materials and devices as may be necessary for the inspection of the Work.

GC 7.06 Maintaining Roads and Detours

Subsection GC 7.06 paragraph .01 is amended by adding the following:

A minimum of one lane of flagged traffic shall be provided during working hours. After working hours, a minimum of one lane of traffic in each direction shall be provided. The Contractor shall be responsible for all costs associated with providing the required traffic control and any traffic detour routes including, but not limited to, the erection and maintenance of all traffic control and detour signage.

Subsection GC 7.06 is amended by adding the following paragraphs:

- .12 The successful Contractor shall submit a traffic management plan showing a method of maintaining pedestrian and vehicular traffic, access to commercial and residential properties, detours, and construction signing in accordance with Contract Documents and the Ontario Traffic Manual – Book 7. The traffic management plan shall be provided by the Contractor to the Contract Administrator at least seven (7) days in advance of the commencement of work to be reviewed for compliance with the requirements of the Contract Document. Construction shall not be permitted to commence without traffic management plan approval. An approved copy of the traffic management plan shall be available for inspection at the project site at all times.
- .13 The Contractor shall give the Contract Administrator fourteen (14) days advance notice prior to any street closing, not including Saturdays, Sundays, or Statutory Holidays, to allow adequate public notification.
- .14 The Contractor shall notify all emergency services and bus services of all lane closures, detours and access restrictions due to construction prior to implementation of or changes to the same.

GC 7.13 Obstructions

Add paragraphs .04, .05 and .06 to subsection GC 7.13 as follows:

- .04 The work may be in close proximity to certain existing utilities such as streetlights, hydro poles, and underground hydro cables. Where utility poles are located at a distance of less than 1.5m from the edge of trenches, such poles must be supported in a manner satisfactory to the Contract Administrator and to the owner of the utility pole. Such support shall be carried out at the Contractor's expense and the cost of the work shall be included in the unit prices tendered for the Work unless noted otherwise i.e. a cash allowance item.
- .05 Where existing utilities must be temporarily disturbed or removed in the course of construction of the works under this Contract, such utilities shall be restored as soon as possible to a condition equal to or better than its original condition and to the satisfaction of the owner of the utility and the Contract Administrator. Such restoration shall be carried out at the Contractor's expense and the cost of the work shall be included in the unit prices tendered for the Work.
- .06 Where the existing underground utilities are exposed during the course of the contract, such utilities shall be supported in place and protected from injury in a manner satisfactory to the owner of the utility and the Contract Administrator. Such protection shall be carried out at the Contractor's expense and the cost of the work shall be included in the unit prices tendered for the Work.

GC 7.14 Limitations of Operations

Amend GC 7.14 paragraph .01 with the addition of the following:

Working hours for the Contract will be restricted to between 7:00 a.m. to 7:00 p.m. local time Monday to Friday except in the case of emergencies and as specifically approved in writing by the Contract Administrator. Requests for approval shall be provided by the Contractor to the Contract Administrator a minimum of 48 hours prior to the anticipated date for which approval is required.

GC 7.16 Warranty

Delete GC 7.16 paragraph .02 and replace with the following:

- 02 Subject to the previous paragraph the Contractor shall correct promptly, at no additional cost to the Owner, defects or deficiencies in the Work that appear,
- a) prior to and during the period of 12 months from the date of Substantial Performance of the Work, as set out in the Certificate of Substantial Performance of the Work.
 - b) where there is no Certificate of Substantial Performance, 12 months from the date of Completion of the Work as set out in the Completion Certificate, or
 - c) such longer periods as may be specified in the Contract Documents for certain Materials or some of the Work.

The Contract Administrator shall promptly give the Contractor written notice of observed defects or deficiencies.

Upon receipt of written notice, the Contractor shall resolve the observed defects or deficiencies within 30 calendar days to the satisfaction of the Contract Administrator.

GC 7.18 Drainage

Amend GC 7.18 paragraph .01 by adding the following:

The Contractor will be held responsible for all damage which may be caused or result from water backing up or flowing over, through, from, or along any part of the works, or which any of his operations may cause to flow elsewhere.

GC 8.0 MEASUREMENT AND PAYMENT

GC 8.01.02 Variation in Tender Quantities

Delete the last sentence in subsection GC 8.01.02.01 and replace with the following:

Written requests for compensation must be received within 60 days of the publication of the Certificate of Substantial Performance.

GC 8.02.04.09 Interest for Late Payment

Delete clauses b) and c) of paragraph .01 to subsection GC 8.02.04.09

GC 8.02.09 Liquidated Damages

Add paragraph .02 and .03 to subsection GC 8.02.09 as follows:

- .02 The Contractor shall pay to the Owner liquidated damages of One Thousand Dollars (\$1,000.00) for each and every calendar day that the work or works remains unfinished after the stipulated date of Substantial Performance and/or date of Completion.
- .03 The Owner may deduct Liquidated Damages from any monies that may be due or payable to the Contractor. The Liquidated Damages are payable in addition to and without limiting any other remedy, action or other alternative that may be available to the Owner.

SUPPLEMENTAL SPECIFICATIONS – GENERAL

Part 2 SUPPLEMENTAL GENERAL CONDITIONS

2.1 OWNER AS CONSTRUCTOR

In all cases the Contractor will fulfill his obligations as Constructor for the Work under their control in accordance with the Occupational Health and Safety Act and regulations. In situations where the Owner requires additional parties (utilities, own forces, others) to work within the Limits of Contract, the Owner may do the following:

- 1) enter into a contractual agreement with the Contractor to undertake the project including the work of the additional parties on behalf of Owner, whereby the Contractor assumes control over the project including the work of the additional parties, or
- 2) assume the responsibilities of the Constructor, as defined in the Occupational Health and Safety Act for the duration of the third party Work, or
- 3) where appropriate, may require partitioning of the project to segregate access points (entrances and exits) from other construction operations within the Limits of Contract, in order that the Owner may undertake works without conflicting with other construction operations, or
- 4) make arrangements for the Contractor to vacate the Limits of Contract for the duration of the third party Work in order to undertake works within the Limits of Contract without conflicting with other construction operations.

When the Owner as “Contractor” retains a third party to perform a portion of the Work, the Owner will notify the Contractor of its intention in writing.

2.2 REMOVALS

All removals shall be considered Excess Material and disposed off-site in accordance with OPSS.MUNI 401. There will be no separate measurement for payment for this item; work under this item is considered incidental to the Work.

2.3 RECYCLING, WASTE AND GREEN BIN COLLECTION

The Contractor shall collect and transport to a depot location outside of the Work Area but within 1km of the Work Area limits recycling, waste and green bin containers. The location shall be determined by the Contract Administrator. Upon emptying of the bins by others, the Contractor shall return the containers to their respective owners on the same day. Lost or damaged containers shall be replaced by the Contractor in kind. Collection frequency varies by street but may be up to two (2) times a week in some locations. The Contractor shall supply all labour, material and equipment required to complete the work. There will be no separate measurement for payment for this item; work under this item is considered incidental to the Work.

2.4 DRIVEWAY ACCESS AND MAINTENANCE MANAGEMENT

At all times, the Contractor shall provide access to and maintain driveways to pre-construction conditions or as directed by the Contract Administrator. Temporary ramping and associated maintenance is required. Driveways and temporary ramping shall be free of mud, debris, ruts and depressions greater than 50mm. Temporary watermain, sewage bypass pumping and any other temporary works shall be placed below grade or approved ramping used. It is recognized that during underground infrastructure installation in proximity to driveways, placement of curb, sidewalk, granulars and asphalt driveway access will be restricted. Notwithstanding, the contractor shall make all reasonable efforts to provide access such as prompt backfilling of trenches and prompt placement of the road base following underground infrastructure. The contractor shall provide positive drainage of the temporary road surface(s).

The Contractor shall schedule curb and sidewalk as closely as possible. The Contractor shall strive for a maximum driveway restriction of ten (10) calendar days to facilitate both curb and sidewalk construction.

The contractor shall supply and place owner approved door hangers to indicate when driveway access will be restricted. Submit door hangers to Contract Administrator for approval minimum two (2) weeks ahead of intended use. The door hangers shall indicate the date, time and duration of the driveway restriction and provide contact information of the Contractors on-site representative. The door hangers shall be placed 24h in advance of the planned restriction. A restriction is considered but not limited to underground infrastructure installation in proximity to driveways, placement of curb, sidewalk, granulars, asphalt and line markings.

There will be a \$500 penalty assessed for each occurrence on a per driveway basis that in the sole opinion of the Contract Administrator the contractor did not fulfill their obligation under this item including but not limited to providing driveway access, ramping, maintenance and notice in the form of door hangers. A one time \$2,500 bonus will be awarded if, in the sole opinion of the Contract Administrator the Contractor fulfilled their obligations under this item.

There will be no separate measurement for payment for this item; work under this item is considered incidental to the Work.



SUPPLEMENTAL SPECIFICATIONS SEWERS

SUPPLEMENTAL SPECIFICATIONS - SEWERS

Part 1 AMMENDMENTS TO ONTARIO PROVINCIAL STANDARDS FOR ROADS AND PUBLIC WORKS

OPSS.MUNI 401 CONSTRUCTION SPECIFICATION FOR TRENCHING, BACKFILLING AND COMPACTION

401.05.01 Bedding and Embedment Material

Section 401.05.1 is deleted and replaced with the following:

Bedding and Embedment Material shall be Granular B , Type I, II or III, with 100% passing the 26.5mm sieve.

401.05.02 Cover Material

Section 401.05.02 is deleted and replaced with the following:

Cover material shall be Granular B , Type I, II or III, with 100% passing the 26.5mm sieve.

401.05.04 Backfill Material

401.05.04.01 General

Section 401.05.04.01 is deleted and replaced with the following:

Backfill material shall be Granular B, Type I, II or III, with 100% passing the 26.5mm sieve. Where specified or approved by the Contract Administrator, suitable native material may be used for backfill.

401.07 CONSTRUCTION

401.07.10 Backfilling and Compacting

401.07.10.03 Bedding

The first paragraph of subsection 401.07.10.03 is deleted and replaced with the following:

Pipe bedding shall be Bedding Class B unless otherwise specified in the Contract Documents.

Subsection 401.07.10.03 is amended by the addition of the following paragraph:

Where trench conditions exhibit seeping water in silt or fine sand, a change from specified bedding to non-woven Class 1 geotextile wrapped 19mm clear stone is required, as determined by the Contract Administrator. Once this change is made (mid run), this bedding system will be maintained until the next maintenance hole location regardless if the trench conditions improve. Trench conditions will be re-evaluated at the beginning of each run to determine if geotextile wrapped clear stone is warranted.

401.10 BASIS OF PAYMENT

401.10.01 Trenching, Backfilling, and Compacting

Paragraph 4 of Subsection 401.10.01 is deleted and replaced with the following:

Where native material is specified for reuse:

Where native material is specified for reuse and the native material or portions thereof, is deemed unsuitable for backfill for reasons other than those attributed to the Contractor's mode of operation, any extra work done to provide acceptable backfill beyond the work herein specified shall be paid for through the appropriate provisional tender item or as Extra Work where a provisional backfill item is not included in the form of tender.

OPSS.MUNI 405 CONSTRUCTION SPECIFICATION FOR PIPE SUBDRAINS

405.05 MATERIALS

405.05.01 General

Paragraph 3 of Subsection 405.05.01 is deleted and replaced with the following:

All subdrains shall be 150 mm diameter unless otherwise specified in the Contract Documents.

Subdrain perforations in polyvinyl chloride (PVC) or corrugated steel pipe shall consist of 6mm holes in four rows positioned at 4, 5, 7 and 8 o'clock and 75mm apart longitudinally, or approved equivalent.

Outlets shall be constructed of non-perforated corrugated steel pipe, PVC pipe, or double-walled polyethylene having a CSA certified minimum pipe stiffness of 320 kPa.

Subdrains under all hard surfaced areas shall have a CSA certified minimum pipe stiffness of 320 kPa.

405.07 CONSTRUCTION

405.07.01 General

Subsection 405.07.01 is amended by the addition of the following:

Minimum grade for pipe subdrains shall be 0.25 %. Grades shall be set using a laser where the grades are less than 1 %.

The Contractor shall install minimum 1.5m length at minimum 0.5% of 200mm dia. non-perforated PVC SDR 35 320 KPa stiffness pipe at all subdrain connections to catchbasins. The flexible subdrain shall be neatly cut and inserted minimum 0.3m into the 200mm dia. PVC. The 200mm dia. pipe shall be grouted smooth trowel finish at the catchbasin connection.

405.07.04 Geotextile

Subsection 405.07.04 is deleted and replaced with the following:

Subdrain shall be wrapped with a knitted sock geotextile.

Subdrains shall have 19 mm clear stone embedment and the subdrain trench and outlet pipe trench shall be wrapped with non-woven Class I geotextile with a filtration opening size of 300 µm.

405.07.06 Laying Subdrain and Outlet Pipe

405.07.06.03 Connections to Drainage Structures

All catchbasins to be installed in hard surface areas shall be provided with a 200mm knockout on both sides of the catchbasin at subgrade elevation for the connection of subdrains.

OPSS.MUNI 407 CONSTRUCTION SPECIFICATION FOR MAINTENANCE HOLE, CATCH BASIN, DITCH INLET AND VALVE CHAMBER INSTALLATION

407.05 MATERIALS

407.05.05 Adjustment Units

Paragraph 2 of Subsection 407.05.05 is deleted and replaced with the following:

Rubber adjustment units are not approved for use.

Subsection 407.05.05 is amended by the addition of the following:

All adjustment units installed in hard surfaced areas shall be precast concrete.

Where curb inlets are specified in the contract documents, curb inlet catch basins shall be provided with cast in place adjustment to grade in accordance with OPSD 400.090.

407.05.07 Frames With Covers or Grates

Subsection 407.05.07 is amended by the addition of the following:

Frames and covers for sanitary sewer maintenance holes shall be in accordance with OPSD 401.010, Type A - Closed Cover unless otherwise specified in the Contract Documents.

Frames and covers for storm sewer maintenance holes shall be in accordance with OPSD 401.010, Type B - Open Cover, unless otherwise specified in the Contract Documents.

Frames and grates for catch basins and catch basin maintenance holes shall be in accordance with OPSD 400.100, unless otherwise specified in the Contract Documents.

Frames and grates for ditch inlet catch basins and ditch inlet catch basin maintenance holes shall be in accordance with OPSD 403.011, unless otherwise specified in the Contract Documents.

407.07 CONSTRUCTION

407.07.01 General

Subsection 407.07.01 is amended by the addition of the following:

Where top asphalt is to be deferred over a winter season or longer, catch basin grates shall be constructed to base asphalt elevation, and an asphalt curb shall be installed around the grate. Prior to top asphalt being applied, catch basins shall be raised to finished grade and concrete curb installed.

407.07.13 Installation of Inlet and Outlet Pipes Into Concrete Structures

Subsection 407.07.13 is amended by the addition of the following:

All pipes shall be fully sealed into place with non-shrink grout and the inside of the structure finished to a smooth steel trowel finish.

All flexible pipe connections to concrete structures shall be made with a pre-manufactured flexible pipe connection provided within 300 mm of the outside face of the structure or with a flexible, watertight resilient connector in the structure opening.

407.07.14 Benching and Channeling

Subsection 407.07.14 is amended by the addition of the following:

All storm and sanitary maintenance holes shall be benched in accordance with OPSD 701.021.

Sanitary maintenance holes shall be benched to the full height of the inlet and outlet pipes.

407.07.16 Installation of Frames with Grates or Covers

Subsection 407.07.16 is amended by the addition of the following:

Precast concrete adjustment units shall be fully parged with non-shrink grout complete with a smooth and neat steel trowel finish. Parging shall be completed around the entire exterior of the lid and adjustment units down to the joint with the first riser/cap. Ensuring no exposed joints are present from lid bottom to the riser/cap.

407.07.17 Installation of Aluminum Safety Platforms

Subsection 407.07.17 is amended by the addition of the following:

Aluminum safety platforms shall be provided on all maintenance holes where the total depth from top of the frame and cover to invert of the outlet exceeds 5.0 metres.

407.10 BASIS OF PAYMENT

Subsection 407.10.02 is deleted and replaced with the following:

When the Owner raises or lowers a pipe invert in a maintenance hole by up to and including 300 mm, it shall not constitute a Change in the Work and no adjustment shall be made to the payment. Where a pipe invert in a maintenance hole is raised or lowered by more than 300 mm, this shall constitute a Change in the Work for the full extent of the change from the original grade.

OPSS.MUNI 408 CONSTRUCTION SPECIFICATION FOR ADJUSTING OR REBUILDING MAINTENANCE HOLES, CATCH BASINS, DITCH INLETS, AND VALVE CHAMBERS

408.07 CONSTRUCTION

408.07.01 CONSTRUCTION

Paragraph 2 is deleted and replaced with the following:

All structures shall be adjusted or rebuilt plumb, true to alignment and grade and flush with surrounding grade.

OPSS 409.MUNI CONSTRUCTION SPECIFICATION FOR CLOSED CIRCUIT TELEVISION INSPECTION OF PIPELINES

409.07 CONSTRUCTION

409.07.05 Final Documentation

409.07.05.01 Survey Reporting

Subsection 409.07.05.01 is amended by the addition of the following:

All interim reports and video records shall be made available to the Contract Administrator at any time during or after the video inspection process and cannot be withheld from the Contract Administrator for any period of time for any reason. The Contractor is required to surrender all videos or other video evidence of any kind at any time or at any stage of the videotaping process if requested by the Contract Administrator.

Provisions shall be made for the Contract Administrator to witness the pipeline video during the videoing process, if requested.

Final reports shall be submitted to the Contract Administrator within 10 working days of the completion of the field work and prior to placement to the pavement or base asphalt as a condition of authorization to pave base asphalt.

OPSS.MUNI 410 CONSTRUCTION SPECIFICATIONS FOR PIPE SEWER INSTALLATION IN OPEN CUT

410.05 MATERIALS

410.05.01 PIPE MATERIALS

410.05.01.01 General

Subsection 410.05.01.01, is amended by the addition of the following:

All polyvinyl chloride (PVC), high-density polyethylene (HDPE), and Polypropylene (PP) sewer pipe shall be CSA certified to have a minimum pipe stiffness of 320 kPa and water-tight joints to 100 kPa unless otherwise specified in the Contract Documents.

Ribbed PVC pipe shall not be used for storm or sanitary sewers.

Polypropylene (PP) sewer pipe shall be triple wall with smooth exterior and shall only be used for pipe size 750mm to 1500mm in diameter, unless otherwise specified in the Contract Documents.

Concrete pipe material must comply with the following CSA requirements:

1. Non-Reinforced - CAN/CSA257.1 100mm - 600mm
2. Reinforced - CAN/CSA257.2

All fabricated and moulded fittings shall be CSA certified.

410.07 CONSTRUCTION

410.07.12 Pipe Installation

410.07.12.01 General

Subsection 410.07.12.01, paragraph 5 is deleted in its entirety and replaced with the following:

When the Owner raises or lowers the invert of a pipe sewer by 300 mm or less, it shall not constitute a Change in the Work and no adjustment shall be made to the payment. When the invert of a pipe sewer is raised or lowered by more than 300 mm, it shall constitute a Change in the Work for the full extent of the change from the original grade.

410.07.13 Service Connections

Subsection 410.07.13 is deleted in its entirety, and replaced with the following:

Service connections to the main pipe sewer shall be made using factory tees, unless otherwise specified in the Contract Documents.

When existing service connections shall be connected to new pipe sewers or service connections, proper jointing procedures shall be used.

Factory tees for PVC service connections to concrete main pipe sewers shall be manufactured with a two-step/gasket system and grouted around the service connection on the outside of the tee after the connection is made.

Where horizontal or vertical bends are required in service connections, long radius sweeps shall be used. Short bends are not acceptable.

For greenfield construction, service connections shall be plugged at the property line with watertight caps or plugs. Plugs or caps shall be braced sufficiently to withstand test pressures.

Service connections shall have a minimum grade of 2% unless otherwise specified in the contract documents or approved by the Contract Administrator.

For main pipe sewers where the depth is 4.5 metres or less, service connections to the main pipe sewer shall be at a grade no greater than 100% (45 degrees) unless otherwise specified in the contract documents or approved by the Contract Administrator.

Where the main pipe sewer is greater than 4.5 metres in depth, service connections to the main pipe sewer shall be provided with a vertical riser in accordance with Drawing S-04.

Sanitary Sewer Service Connections

Service connections for sanitary private drain connections (PDCs) shall be 150 mm diameter PVC SDR 28 unless otherwise specified in the Contract Documents.

Sanitary PDCs pipe shall be white in color.

Sanitary PDCs shall not be connected to a maintenance hole.

Storm Sewer Service Connections

Service connections for storm PDCs shall be 100 mm diameter PVC SDR 28 unless otherwise specified in the Contract Documents

Storm PDCs pipe shall be green in color.

Connections for catch basin leads connected to a maintenance hole shall not exceed 1.80 m above the invert of the outlet sewer.

Catch basin leads for single catch basins shall be 250 mm diameter PVC SDR 35 unless otherwise specified in the Documents. Catch basin leads for maintenance hole catch basins, double catch basins or multiple catch basins shall be 300 mm diameter unless otherwise specified in the Contract Documents.

Service Connections to Existing Pipe Sewers

Where service connections are made to existing main pipe sewers, holes in the main pipe sewer shall be cut with approved cutters and shall be the minimum diameter required to accept the service connection saddle. If mortar-on saddles are used, the inside of the pipe shall be mortared at the connection.

Existing concrete main pipe sewers may be core drilled and fitted with a Core Bell Concrete Adaptor (for sizes 100mm – 250mm only), CoreBoot PVC to Concrete Pipe Connector or approved equal.

Service connections to existing smooth-wall PVC main pipe sewers shall be core drilled and fitted with an “Inserta Tee” connector, or approved equal.

Service connections to existing ribbed PVC main pipe sewers shall be made with manufactured tees. When conditions do not permit, as determined by the Contract Administrator, an “Inserta Tee” or approved equal shall be used.

Manufactured tees shall be used for connections to HDPE annular profile pipe. When conditions do not permit, as determined by the Contract Administrator, an “Inserta T” connector shall be used.

Service connections to existing Vitrified Clay main pipe sewer shall be made using a manufactured boot and a fabricated PVC Tee.

Service connections to existing Asbestos Cement main pipe sewer shall be made with a cast iron saddle.

For service connections to Lined Vitrified Clay or Asbestos Cement main pipe sewer where an existing service connection is to be removed and replaced, the existing hole in the main sewer pipe is to be trimmed smooth and a saddle tee (Fernco EZ Tap Sewer Saddle or approved equal), shall be used to make the connection for a new private drain connection. A sand/cement (250mm slump) mixture is to be placed around the void that was made to slip the strap around the main sewer pipe to mitigate settlement.

410.07.14 Marking and Recording Service Connections

Clause 410.07.14, second paragraph, is deleted in its entirety and replaced by the following:

Painted surface stakes 40mm X 90mm X 450mm (standard 2" X 4") long shall be placed after trench restoration to mark the termination of storm and sanitary services (PDCs) respectively.

Markers for Sanitary PDCs shall be painted white in color.

Markers for Storm PDCs shall be painted green in color.

410.07.16 Field Testing

410.07.16.01 General

Subsection 410.07.16.01 is amended with the addition of the following:

Leakage testing shall be carried out on all sanitary sewers installed in new development.

Deflection testing shall be carried out on all flexible mainline storm or sanitary pipe sewers.

410.07.16.06 Closed-Circuit Television (CCTV) Inspection

Clause 410.07.16.06 is amended by the addition of the following:

The Contractor shall undertake a video inspection for all mainline pipe sewers installed, and of existing main pipe sewers following the connection of new or replacement service connections.

410.07.17 Cleaning and Flushing Pipe Sewers

Clause 410.07.17 is amended by the addition of the following:

The Contractor will not be permitted to flush the new sewer lengths into existing sewers. The Contractor shall provide and place temporary plugs where necessary to prevent silt and debris from entering existing sewers.

**OPSS 412.MUNI CONSTRUCTION SPECIFICATIONS FOR SEWAGE
FORCEMAIN INSTALLATION IN OPEN CUT****412.05 MATERIALS****412.05.01 General**

Subsection 412.05.01 is amended by the addition of the following:

Corrosion protection shall be provided for sewage forcemains in accordance with OPSS.MUNI 442 and the Supplemental Specifications – Water, Section 2.3, Corrosion Protection.

Tracer wire shall be provided with all sewage forcemains in accordance with the Supplemental Specifications – Water, Section 2.5, Tracer Wire.

412.05.04 Polyvinyl Chloride Plastic Pressure Pipe Products

Subsection 412.05.04 is amended by the addition of the following:

All PVC pipe and fittings for sewage forcemain shall be white in colour.

412.05.05 Polyethylene Plastic Pressure Pipe Products

Subsection 412.05.05 is amended by the addition of the following:

All polyethylene plastic pipe and fittings for sewage forcemain shall be manufactured with green colour stripe indicating it conveys sanitary sewage.

412.07 CONSTRUCTION**412.07.16 Thrust Restraints**

Subsection 412.07.16 is deleted and replaced with the following:

Concrete thrust blocks shall not be used as thrust restraint unless otherwise specified in the Contract Documents. All thrust restraint shall be designed to adequately provide the minimum amount of pipe/joint restraint required by mechanical restraint device alone.

Thrust restraint shall be provided at all connections, caps, fittings, bends, valves, or reducers. Thrust restraints shall be shown on the shop drawings as recommended by the pipe manufacturer and approved by the Contract Administrator.

412.07.18 Cleaning and Flushing Force mains

Subsection 412.07.18 is amended by the addition of the following:

Sewage force mains shall be cleaned by use of a minimum of two (2) foam swabs in order to remove debris which may have entered the force main during construction. Cleaning shall be repeated until consecutive swabs are clean and the discharge water is clear.

Cleaning and flushing of sewage force mains shall follow the swabbing procedure identified in OPSS.MUNI 441 as amended by the Supplemental Specifications – Watermain

OPSS.MUNI 421 CONSTRUCTION SPECIFICATION FOR PIPE CULVERT INSTALLATION IN OPEN CUT

421.05 MATERIALS

421.05.01 Pipe Materials

421.05.01.01 General

Subsection 421.05.01.01 is amended by the addition of the following:

All pipe culverts shall be double-walled high-density polyethylene (HDPE) unless otherwise specified in the Contract Documents.

421.05.01.04 Polyethylene Pipe Products

Subsection 421.05.01.04 is amended by the addition of the following:

Polyethylene pipe culverts shall be double-walled high-density polyethylene (HDPE). HDPE pipe culverts shall be CSA certified to have a minimum pipe stiffness of 320 kPa, and shall have water-tight joints to 75 kPa.

421.07 CONSTRUCTION

421.07.12 Pipe Installation

421.07.12.01 General

Paragraph 5 of Subsection 421.07.12.01 is deleted and replaced with the following:

When the Owner raises or lowers the invert of a pipe culvert by up to 300 mm, it shall not constitute a Change in the Work and no adjustment shall be made to the payment. When the invert of a pipe culvert is raised or lowered by more than 300 mm, then this shall constitute a Change in the Work for the full extent of the change from the original grade.

OPSS.MUNI 510 CONSTRUCTION SPECIFICATION FOR REMOVAL

510.10 Basis of Payment

510.10.01 Removal of Item

Paragraph 2 of Subsection 510.10.01 is deleted and replaced with the following:

Imported Granular B, Type I, II or III backfill shall be included in the tender item for the removal specified in Contract Documents.

SUPPLEMENTAL SPECIFICATIONS – SEWERS

Part 2 SUPPLEMENTAL SPECIFICATIONS FOR SEWERS

2.1 INVESTIGATE UNKNOWN SANITARY SERVICES

Where sanitary service connection to a dwelling is marked as unknown or unclear on the contract drawings, the contractor shall carry out a detailed inspection to verify location, depth and elevation of the sanitary private drain connection prior to installation of the sanitary mainline tee.

The work to investigate unknown sanitary services shall include video inspection, tracing and locating the private drain connection from a clean-out or fixture in the dwelling to the mainline tee, and excavating to and exposing the private drain connection at property line. The contractor shall obtain written authorization from the homeowner prior to any work on private property.

There will be no separate measurement for payment for this item; work under this item is considered incidental to the Work.

2.2 MANHOLE INSERTS

Manhole inserts shall be installed in locations specified by the Contract Documents. Inserts shall be Parson Manhole vented non-valve type or approved equivalent. Maintenance hole frame rim shall be cleaned of all dirt and debris prior to installing the insert.

SUPPLEMENTAL SPECIFICATIONS – SEWERS

Part 3 SUPPLEMENTAL STANDARD DRAWINGS FOR SEWERS

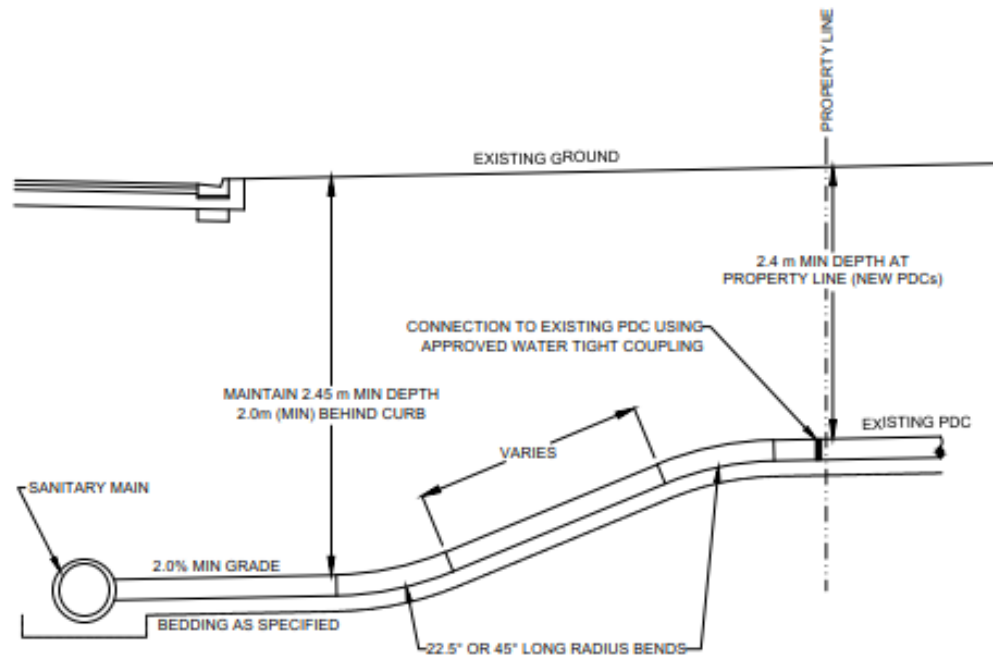

NOTES:

1. SANITARY SEWER SERVICE CONNECTIONS (PDC) SHALL BE 150mm DIAMETER MINIMUM.
2. SEWER SERVICE CONNECTIONS FOR RIGID PIPE - REFER TO OPS 1006.01.
3. SEWER SERVICE CONNECTIONS FOR FLEXIBLE PIPE - REFER TO OPS 1006.02.

NOT TO SCALE
ALL DIMENSIONS IN MILLIMETERS UNLESS OTHERWISE NOTED

STANDARD DRAWING

**TYPICAL SANITARY SEWER
SERVICE CONNECTION**

REVISION DATE: 26 NOV 2021
DRAWING #: **S-01**

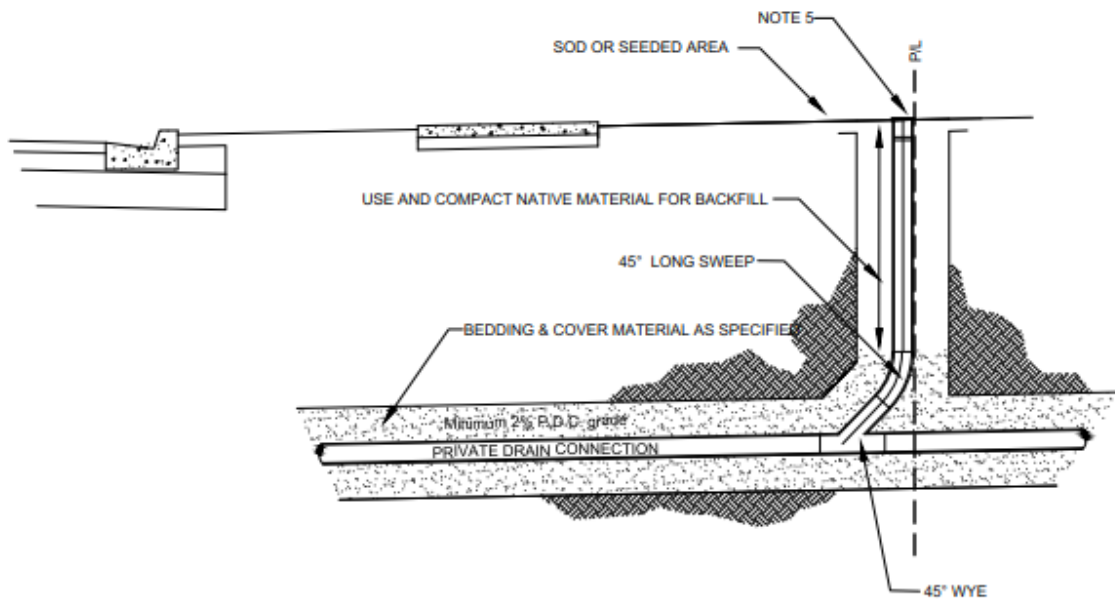

NOTES

1. THE PIPE DIAMETER OF THE CLEANOUT PIPE SHALL EQUAL THE PIPE DIAMETER OF THE P.D.C.
2. THE MINIMUM INSIDE DIAMETER FOR SANITARY P.D.C. CLEANOUT IS 100mm.
3. APPROVED PREFABRICATED WYES AND LONG RADIUS SWEEPS SHALL BE USED FOR ALL P.D.C. CLEANOUT CONNECTIONS.
4. WHERE APPLICABLE, APPROVED END CAPS ARE REQUIRED AT PROPERTY LINE TO COMPLETE THE P.D.C. INSTALLATION. THEY SHALL BE BRACED TO WITHSTAND PRESSURE TESTING WHEN REQUIRED.
5. CLEANOUT COVERS:
 - a. CLEANOUT HARD (RIGID) SURFACE INSTALLATION: USE CAST IRON CAP AND INTALL FLUSH WITH SURFACE.
 - b. CLEANOUT GRAVEL SURFACE INSTALLATION: USE CAST IRON CAP PER A), INSTALL 75mm BELOW FINISHED GRADE.
 - c. CLEANOUT SOFT SURFACE (GRASS) INSTALLATION: USE STANDARD PLASTIC CAP, WITH PEAK FLUSH WITH GRASS SURFACE.

NOT TO SCALE
ALL DIMENSIONS IN MILLIMETERS UNLESS OTHERWISE NOTED

STANDARD DRAWING

**PRIVATE DRAIN CONNECTION
CLEAN OUT**

REVISION DATE: 26 NOV 2021
DRAWING #: **S-02**

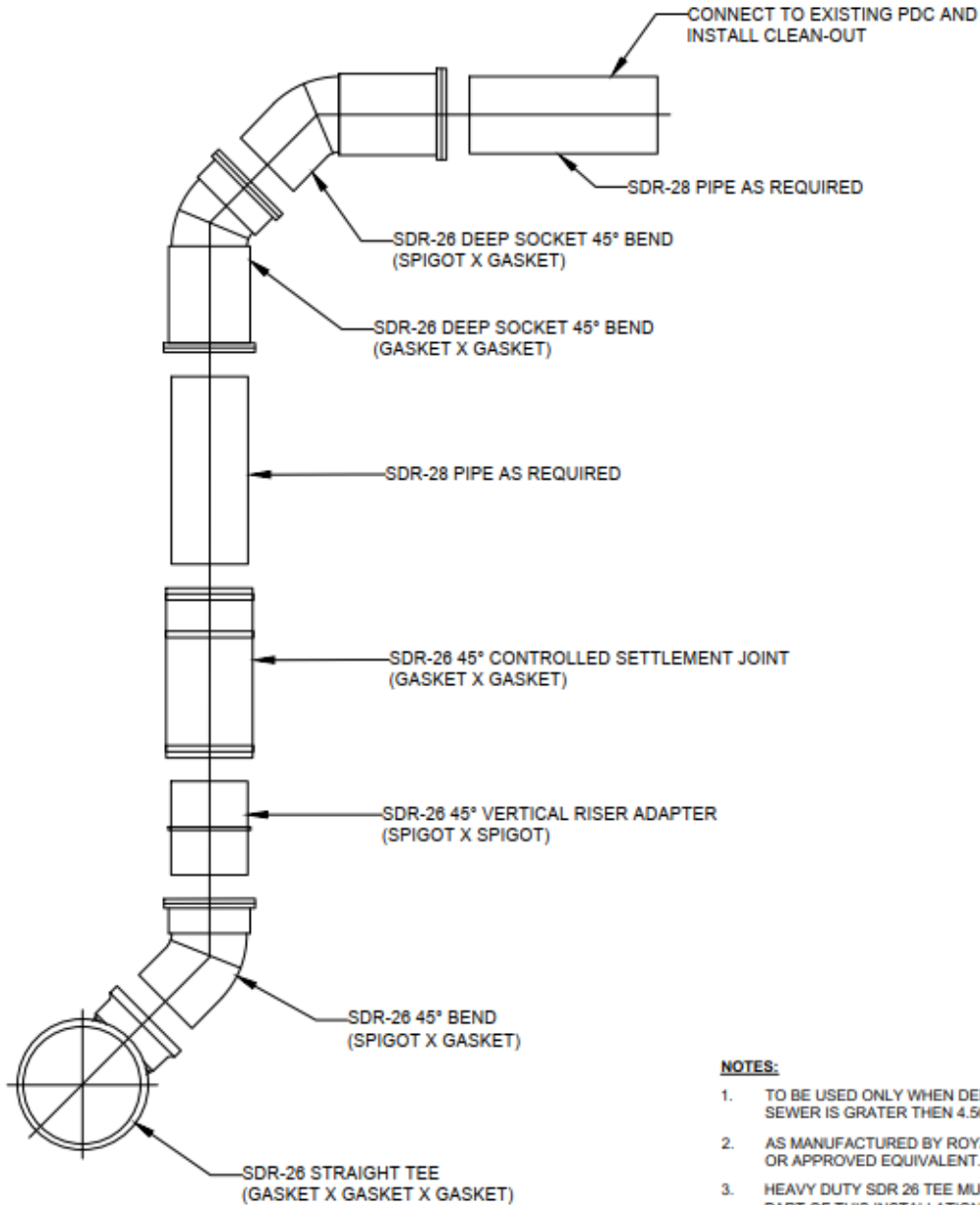

NOTES:

1. TO BE USED ONLY WHEN DEPTH OF SANITARY SEWER IS GRATER THEN 4.50m.
2. AS MANUFACTURED BY ROYAL PIPE SYSTEMS OR APPROVED EQUIVALENT.
3. HEAVY DUTY SDR 26 TEE MUST BE USED AS PART OF THIS INSTALLATION.
4. BEDDING FOR THIS INSTALLATION SHALL BE 19MM CLEAR STONE BEDDING.

NOT TO SCALE
ALL DIMENSIONS IN MILLIMETERS UNLESS OTHERWISE NOTED

STANDARD DRAWING

**PRIVATE DRAIN CONNECTION
VERTICAL RISER INSTALLATION**

REVISION DATE: 26 NOV 2021
DRAWING #: **S-04**

ALTERNATE STANDARD HEIGHTS	
ALTERNATIVE	DIMENSION
A	1980
B	1830
C	1520
D	1380

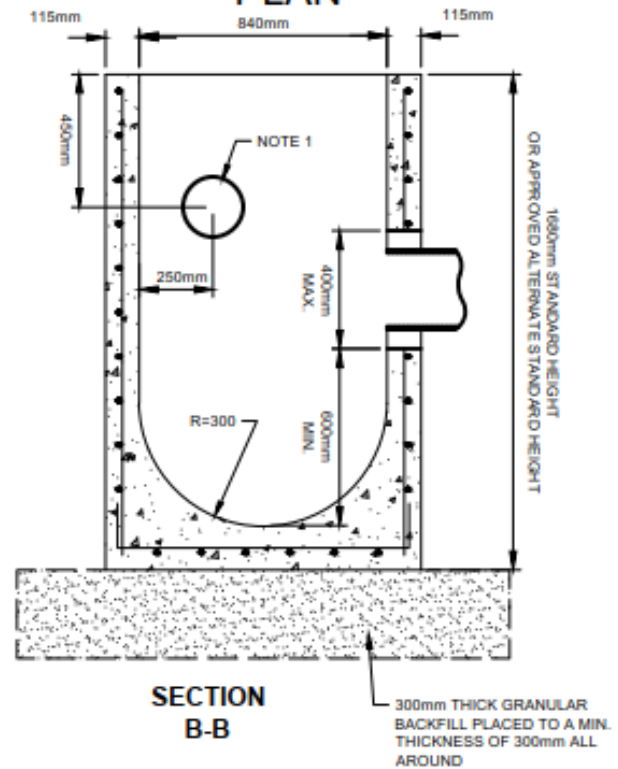
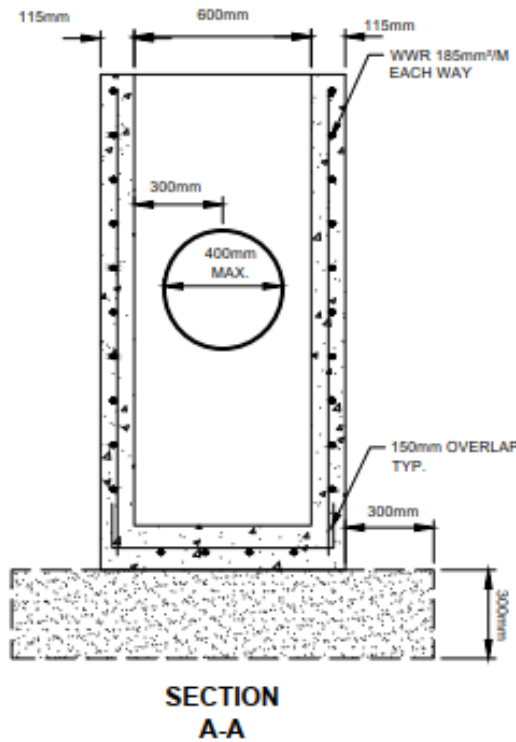
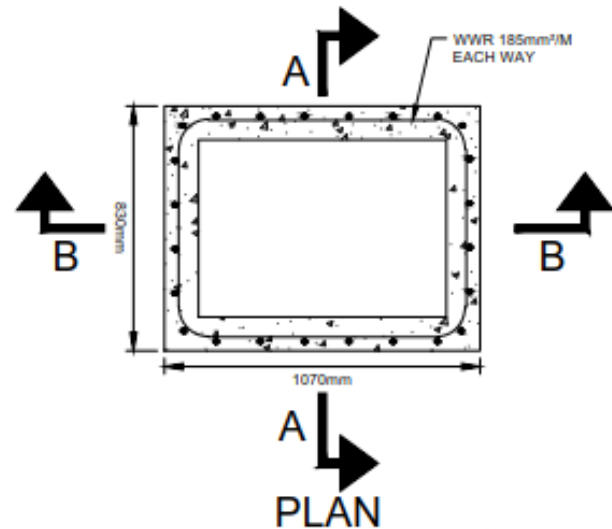

NOTES:

1. 200mmØ KNOCKOUT TO ACCOMMODATE SUBDRAIN. KNOCKOUT TO BE HALF WALL THICKNESS FROM OUTSIDE
2. ADJUSTMENT UNITS SHALL BE AS PER CITY OF ST. THOMAS CONTRACT DOCUMENTS
3. CONCRETE SHALL BE 30MPa
4. REFER TO OPSD 400.09 AND CITY OF ST. THOMAS DRAWING S-04 FOR CURB INLET OVERFLOW DETAILS

NOT TO SCALE
ALL DIMENSIONS IN MILLIMETERS UNLESS OTHERWISE NOTED

STANDARD DRAWING

**PRECAST 600mm x 840mm
CURB INLET CATCHBASIN**

REVISION DATE: 26 NOV 2021
DRAWING #: **S-05**

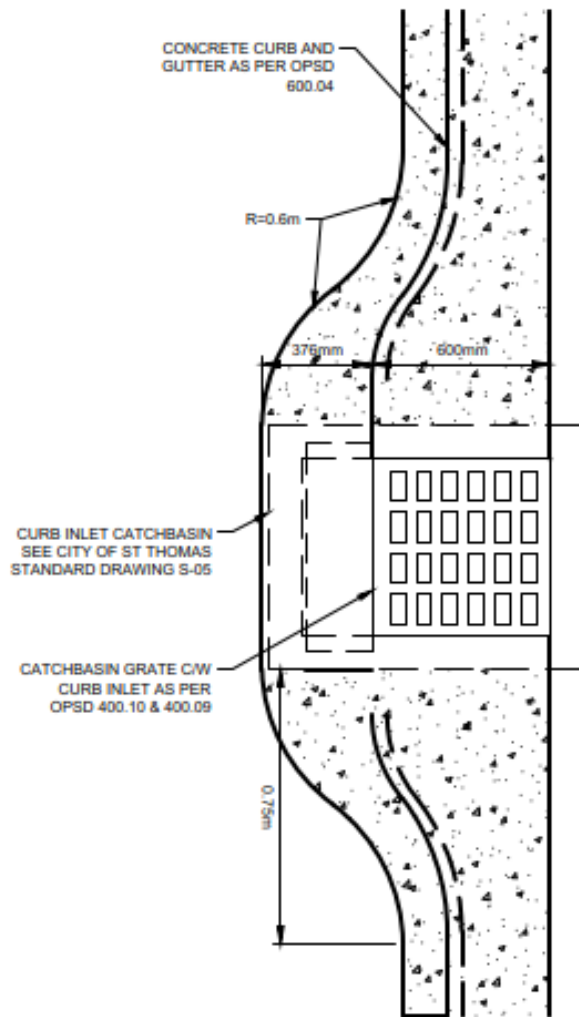

CURB INLET LAYOUT

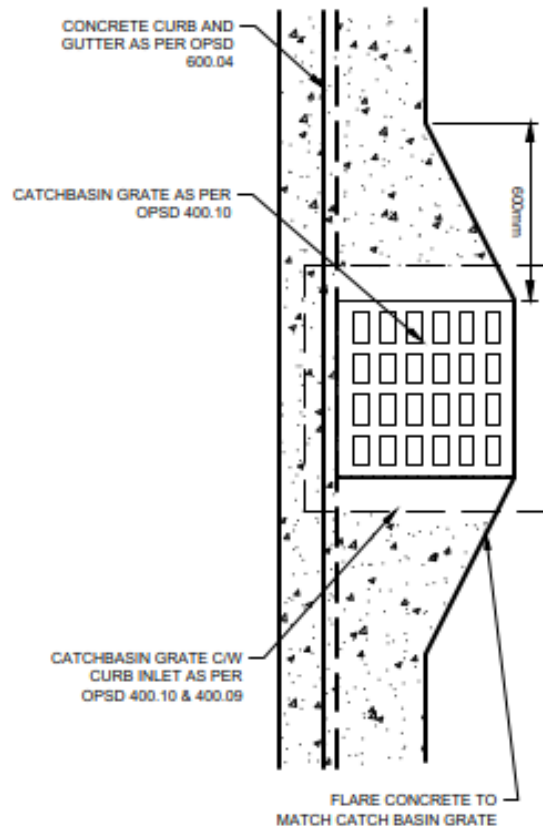

STD. CATCHBASIN LAYOUT

NOT TO SCALE
ALL DIMENSIONS IN MILLIMETERS UNLESS OTHERWISE NOTED

STANDARD DRAWING

CATCHBASIN INLET DETAILS

REVISION DATE: 26 NOV 2021
DRAWING #: **S-06**



SUPPLEMENTAL SPECIFICATIONS WATER

SUPPLEMENTAL SPECIFICATIONS - WATER

Part 1 AMMENDMENTS TO ONTARIO PROVINCIAL STANDARDS FOR ROADS AND PUBLIC WORKS

OPSS.MUNI 401 CONSTRUCTION SPECIFICATION FOR TRENCHING, BACKFILLING AND COMPACTION

401.05.01 Bedding and Embedment Material

Section 401.05.1 is deleted and replaced with the following:

Bedding and Embedment Material shall be Granular B , Type I, II or III, with 100% passing the 26.5mm sieve.

401.05.02 Cover Material

Section 401.05.02 is deleted and replaced with the following:

Cover material shall be Granular B , Type I, II or III, with 100% passing the 26.5mm sieve.

401.05.04 Backfill Material

401.05.04.01 General

Section 401.05.04.01 is deleted and replaced with the following:

Backfill material shall be Granular B , Type I, II or III, with 100% passing the 26.5mm sieve. Where specified or approved by the Contract Administrator, suitable native material may be used for backfill.

401.07 CONSTRUCTION

401.07.10 Backfilling and Compacting

401.07.10.03 Bedding

The first paragraph of subsection 401.07.10.03 is deleted and replaced with the following:

Pipe bedding shall be Bedding Class B unless otherwise specified in the Contract Documents.

401.10 BASIS OF PAYMENT

401.10.01 Trenching, Backfilling, and Compacting

Paragraph 4 of Subsection 401.10.01 is deleted and replaced with the following:

Where native material is specified for reuse:

Where native material is specified for reuse and the native material or portions thereof, is deemed unsuitable for backfill for reasons other than those attributed to the Contractor's mode of operation, any extra work done to provide acceptable backfill beyond the work herein specified shall be paid for

through the appropriate provisional tender item or as Extra Work where a provisional backfill item is not included in the form of tender.

OPSS.MUNI 441 CONSTRUCTION SPECIFICATION FOR WATERMAIN INSTALLATION IN OPEN CUT

441.05 MATERIALS

441.05.01 General

Subsection 441.05.01 is amended by the addition of the following:

All watermain pipe shall be polyvinyl chloride (PVC) Class 235 DR 18 or molecularly oriented polyvinyl chloride (PVCO) Class 235 unless otherwise specified in the Contract Documents.

All potable water services shall be cross-linked polyethylene (PEX) unless otherwise specified in the Contract Documents.

441.05.02 Ductile Iron Pipe

Subsection 441.05.02 is amended by the addition of the following:

Ductile Iron (DI) pipe shall be thickness Class 52 and shall have cement mortar lining and polyethylene encasement unless otherwise specified in the Contract Documents. Polyethylene encasement shall conform to AWWA C105. Electrical continuity shall be provided by means of copper strips, wedges or other approved devices.

The working pressure rating for Ductile Iron pipe shall be 350 psi.

441.05.04 Polyvinyl Chloride Pipe

441.05.04.01 General

Subsection 441.05.04.01 is amended by the addition of the following:

All fittings on PVC pipe 200 mm diameter and smaller shall be polyvinyl chloride.

Ductile Iron push-on fittings are not approved for use with PVC pipe. Mechanical joint Ductile Iron fittings shall be used when they are an integral part of the restraining system.

441.05.04.02 Polyvinyl Chloride Pipe

Subsection 441.05.04.02 is amended by the addition of the following:

Polyvinyl chloride (PVC) pipe up to and including 300 mm diameter shall be Class 235 DR 18 and shall have Cast Iron O.D. dimensions.

441.05.04.03 Molecularly Oriented Polyvinyl Chloride Pipe (PVCO)

Subsection 441.05.04.03 is amended by the addition of the following:

Molecularly Oriented Polyvinyl Chloride Pipe (PVCO) pipe up to and including 300 mm diameter shall be CSA certified to B137.3.1 with a pressure class of 1620 kPa (235 psi) and shall have Cast Iron O.D. dimensions.

Molecularly Oriented Polyvinyl Chloride Pipe (PVCO) pipe is not approved for pipe sizes greater than 300mm diameter.

441.05.05 Polyethylene Pipe

Subsection 441.05.05 is amended by the addition of the following:

Polyethylene Pipe shall be Class 160 DR 11 unless otherwise specified in the Contract Documents. Polyethylene Pipe shall be manufactured with blue colour stripes indicating potable water.

Cross-Linked Polyethylene (PEX) potable water service tubing for service connections shall be in accordance with ASTM F876-05, ASTM F877-05, CSA-B137.5 and NSF 61.

Minimum size for PEX potable water service tubing is 25mm diameter.

Cross-Linked Polyethylene PEX potable water service tubing is to be used with standard copper O.D. brass fittings. PEX tubing ends to be installed with stainless steel inserts and be installed with tracer wire for its entire length.

441.05.06 Steel Pipe

Subsection 441.05.02 is amended by the addition of the following:

Steel pipe shall be Grade 42 with a minimum wall thickness of 6.35 mm and shall have cement mortar lining and polyurethane surface exterior coating unless otherwise specified in the Contract Documents. Polyurethane surface exterior coating shall conform to AWWA C222.

441.05.07 Copper Pipe

Subsection 441.05.02 is deleted and replaced with the following:

Copper pipe is not approved for use.

An anode shall be provided and installed in accordance with OPSS.MUNI 442 on all existing copper pipes encountered during construction.

441.05.08 Composite Pipe

Subsection 441.05.08 is deleted and replaced with the following.

Composite pipe is not approved for use.

441.05.09 Valves

441.05.09.01 General

Paragraph 1 of Subsection 441.05.09.01 is deleted and replaced with the following:

All valves shall open by operating in a clockwise direction.

Paragraph 1 items a), b), c), and d) of Subsection 441.05.09.01 are deleted and replaced with the following:

- a) Valves less than 75 mm shall be brass or bronze ball valves.
- b) Valves greater than or equal to 75 mm shall be cast or ductile iron gate valves

Subsection 441.05.09.01 is amended by the addition of the following:

Valves for buried installation sizes 100mm to 200mm diameter shall have bell ends. Valves for buried installation sizes 250mm to 400mm diameter shall have mechanical joint ends to provide adequate mechanical thrust restraints.

Valves located in chambers must be flanged faced and supplied with Type 316 stainless steel nuts, bolts and washers.

All flanges, bonnet nuts, nuts, bolts and washers shall be protected from corrosion by using Denso paste, profiling mastic and petrolatum tape (or approved equal).

Shaft spindles shall have O-ring seals of resilient materials.

All valves greater than 300mm located inside of a chamber must be supplied with a geared operator (spur or bevel) as required and operational from the surface. Geared operators shall consist of carburized alloy steel spiral bevel or spur gears with shafts operating in antifriction bearings. Geared operators are to be self-contained units, permanently lubricated and totally enclosed in an impact resistant cast iron housing.

All valves shall be supplied with a valve rod extension. Valve rod extensions shall be 25mm solid square rod manufactured with a bottom end to fit over 50mm square valve nut and top end consisting of a guide plate and 50mm square nut. Valve rod extension shall terminate within 150mm to 300mm of the top of the valve box.

Valves shall be supplied with a 130mm diameter screw type cast iron valve box, guide plate and deep style cover.

441.05.09.02 Service Line Valves

Subsection 441.05.09.02 is amended by the addition of the following:

Main stop service line valves shall be high pressure class brass ball valves with threaded inlet and compression outlet, unless otherwise specified in the Contract Documents.

Curb stop service line valves shall be brass ball valves with compression inlet and compression outlet, unless otherwise specified in the Contract Documents.

Service line valves for 38mm diameter and larger water services shall have a 50mm square operating nut.

All service line valves shall be equipped with a thaw nut connector for tracer wire connection.

441.05.09.03 Gate Valves

Subsection 441.05.09.03 is amended by the addition of the following:

All gate valves must be epoxy coated inside and out (minimum of 3 mm thickness) in accordance with AWWA C550.

441.05.10 Hydrants

Subsection 441.05.10 is amended by the addition of the following:

All hydrants shall open by operating in a clockwise direction.

Fire hydrant laterals shall be PVC DR 18 Class 235 or PVCO Class 235.

Fire hydrant extensions as required for deeper bury are to be obtained from the fire hydrant manufacturer. A maximum of one (1) 300mm extension is permitted per hydrant.

Fire hydrants shall have a chrome yellow high gloss exterior paint over quick dry red oxide primer.

Hydrants shall be installed a minimum of 1.5m from the edge of a driveway.

The hydrant shall have mechanical joints.

All hydrants shall be three-way with two (2) standard hose connections and one (1) STORZ connection. The STORZ nozzle shall be bronze according to ASTM B584 with a cast iron cap painted black.

Approved hydrants are:

Canada Valve	Century
McAvity	M-67 with break flange
AVK	27/00 or 27/80

441.05.12 Service Connection Fittings and Appurtenances

Subsection 441.05.12 is deleted in its entirety and replaced by the following:

Service Saddles

25 mm diameter services may be direct tapped into all sizes of DI and CI watermains except 100 mm diameter. A service saddle must be used for a 25 mm diameter service into a 100 mm diameter main.

Service saddles must be used for all sizes of service into PVC pipe and for 40 mm and 50 mm services into CI and DI pipe.

All saddles shall have AWWA thread outlet.

Saddles for DI and CI and Asbestos Cement pipe shall have ductile iron epoxy body with electro galvanized steel double straps and bolts and shall be installed as per the manufactures specifications using torque wrench.

Saddles for PVC pipe shall be full circumference wide band with stainless steel band, nuts, bolts and outlet. Band shall be Type 304 Stainless Steel of minimum 18 gauge thickness

Couplings

Couplings shall be brass with compression inlet and outlet in accordance to AWWA C800. Couplings shall be full bore.

Service Boxes and Rods

Service boxes for 25mm diameter water services shall be cast iron type to suit curb stop and shall have 25 mm hexagonal brass lid plug. Length shall be adjustable to suit depth of service.

Service boxes for 38mm diameter and larger water services shall be 130mm diameter cast iron screw type with a Bubba base and shall have rod extension. Length shall be adjustable to suit depth of service.

Service rods shall be Type 304 stainless steel of minimum 13 mm diameter including stainless steel cotter pins.

Curb stops shall be provided with a cedar bottom board constructed in accordance with Standard Drawing W-18.

441.07 CONSTRUCTION

441.07.07 Transporting, Unloading, Storing, and Handling Pipe

Subsection 441.07.07 is amended by the addition of the following:

Pipes shall be handled with special care during temperatures below freezing.

Pipe shall be lowered into the trench carefully. Under no circumstances are materials to be dropped. The lining and coatings of pipes shall not be damaged.

441.07.14 Installation of Pipes

Paragraph 3 of Subsection 441.07.14 is deleted and replaced with the following:

When the Owner raises or lowers the invert of a watermain by up to 300 mm, it shall not constitute a Change in the Work and no adjustment shall be made to the payment. When the invert of a watermain is raised or lowered by more than 300 mm, then this shall constitute a Change in the Work for the full extent of the change from the original grade.

Subsection 441.07.14 is amended by the addition of the following:

Pipes shall not be exposed to localized high temperatures except as required for the jointing process.

Pipes shall be laid on the prepared bed, true to the line and grade as shown on the contract drawings. The barrel of each pipe shall be in contact with the shaped bed throughout its full length. The ends of the pipe shall abut against each other so that there is no unevenness along the inside. Grades shall be maintained by laser beams.

Pipe shall be laid with the bell ends facing in the direction of laying. At grades above 10 percent for PVC and DI pipe and 5 percent for concrete pressure pipe and steel bell and spigot pipe, laying shall start at the bottom with the bell ends facing upgrade.

Pipe shall not be laid when, in the opinion of the Contract Administrator, trench conditions are unsuitable.

Use of watermain offsets must be indicated in the Contract Documents or in the case of unforeseen obstructions written approval of the Contract Administrator must be obtained.

Where a connection is being made between the existing watermain system and new watermain being constructed, the new watermain is to be commissioned fully before the connection is made. The existing pipe is to be protected at all times from damage and from the potential of contamination to the system. Any opening made to the existing watermain system for a future connection is not to be made until such time as the connection can be made.

441.07.17 Change in Line and Grade

441.07.17.03 Polyvinyl Chloride Pressure Pipe - PVC and PVCO

Subsection 441.07.17.03 is deleted and replaced with the following:

Axial bending (bending of the pipe barrel) is prohibited.

For PVC pipe any change in direction of the watermain in excess of 50% of the pipes manufacturer's allowable joint deflection shall be made using an appropriate fitting.

441.07.18 Installation of Valves and Fittings

441.07.18.01 General

Subsection 441.07.18.01 is amended by the addition of the following:

Damage to Epoxy coating shall be repaired prior to installation, as per manufacturer's recommendations and shall be certified correct by the manufacturer.

441.07.19 Installation of Hydrant Sets

Subsection 441.07.19 is amended by the addition of the following:

Fire hydrants are to be installed at a grade, whereby the fire hydrant boot has a minimum bury of 1.7m to a maximum bury of 1.9m, measured from the base of the fire hydrant boot to finished grade. In cases where the depth of the watermain is greater than 1.9m, bends may be used to offset the hydrant lateral (past the gate valve) to achieve the standard fire hydrant boot depth. A 300mm (maximum) fire hydrant barrel extension may also be used. All offsets and extensions must be approved and inspected by the Contract Administrator.

Damage to the fire hydrant paint coating shall be repaired prior to installation, in accordance with the manufacturer's recommendations.

Hydrants shall be set at a grade whereby the final grading of the street or area shall be a minimum of 75mm to a maximum of 150mm from the break flange of the hydrant to the final grade. Grading which results in a depression or ponding at the hydrant will not be accepted.

441.07.20 Installation of Services Connections

Subsection 441.07.20 is amended by the addition of the following:

All Service connections shall be installed perpendicular to the watermain from the curb stop to the watermain unless otherwise specified by the Contract Documents or approved by the Contract Administrator.

No service connections to any users or use of the water from a main will be permitted until the main has been cleaned and passed pressure, leakage and disinfection tests.

A surface stake 40mm X 90mm X 450mm long and painted blue shall be placed after trench restoration to mark the termination of a water service.

441.07.21 Shutting Down or Charging Mains

Subsection 441.07.21 is deleted in its entirety and replaced with the following:

The Contractor shall at no time cause watermains that are in service be shut down or charged, or operate any valve or other control for any purpose.

Operation of valves, hydrants, blow-offs and curb stops shall be performed solely by the Owners Water Operator.

At least 24 hour notice must be given to the Owner when valves which will shut off services to consumers are required to be operated. The Contractor shall give written notice of interruption of service to all affected consumers at least 24 hours before the interruption occurs. The notice shall inform the affected consumer of the hour when the water service will be interrupted and the approximate hour that the water service will resume. The Contractor shall obtain notice cards from the Owner and shall distribute them. There will be no separate measurement for payment for this work. Costs for the work shall be considered incidental to the tendered unit rates.

441.07.22 Connections to Existing Watermains

Subsection 441.07.22 is amended with the addition of the following:

All connections to existing watermains shall be made under the supervision of the Owners Water Operator. At least 24 hour notice must be given to the Contract Administrator prior to the connection.

The work of connecting to existing watermains shall include dewatering.

441.07.23 Thrust Restraints

Subsection 441.07.23 is deleted and replaced with the following:

Thrust restraint shall be provided at all fittings, bends, tees, valves, hydrants, crosses, reducers, and plugged or capped dead ends. All fittings and joints 300mm diameter and smaller shall be restrained in accordance with the Standard Drawing W-01. For watermains larger than 300mm diameter or installation situations not included in Standard Drawing W-01, the restrained length shall be shown on the shop drawings as recommended by the pipe manufacturer and approved by the Contract Administrator.

Shop drawings and calculations for thrust restraints for watermains larger than 300mm diameter shall be based upon the following criteria:

- Hydrostatic test pressure is 1035kpa (150psi)
- For poly wrapped DI pipe refer to AWWA C600
- For PVC pipe refer to AWWA C900, UNI-BELL and pipe suppliers manuals;
- Depth of bury is at a minimum of 1.7m (5.5ft)
- Steel rods are to be a minimum of 20mm in diameter
- Trench type shall be Type 3 as per AWWA C150 Trench Conditions (Pipe bedded in 100mm minimum loose soil. Backfill lightly consolidated to top of pipe)
- Joints shall be designed for the same design test and surge pressure rating as the pipeline
- Factor of Safety shall be 2:1
- Soil type shall be CL as per "Unified Soils Classification Systems. ASTM Standard D248

Only restrained joint products specifically designed for use with the pipe material shall be used.

Concrete thrust blocks shall not be used as thrust restraint unless otherwise specified in the Contract Documents. All thrust restraint shall be designed to adequately provide the minimum amount of pipe/joint restraint required by mechanical restraint device alone.

All joint thrust restraint devices must meet or exceed the minimum requirements of ASTM F 1674-96 and shall be UL listed and FM approved.

Restraining glands 100mm diameter to 300mm diameter shall be manufactured of high strength ductile iron conforming to the requirements of ASTM A536, Grade 65 45 12 (minimum). Restraining glands 400mm diameter to 600 mm diameter shall be manufactured of structural steel conforming to the requirements of ASTM A36. Restrain devices shall incorporate a series of machine serrations on the inside diameter to provide 360 degree contact and support of the pipe wall.

Joints shall be designed for the same design, test and surge pressure ratings as the pipeline in accordance with AWWA-M23

All restraints are to be torqued to manufacturer's specifications using a calibrated torque wrench. If power equipment is used during installation, it is to be set as not to over tighten the bolts before they are properly torqued.

For installation of thrust restraints on DI pipe refer to AWWA C600. For installation of thrust restraints on PVC pipe refer to UNI-BELL, AWWA M-23 and ASTM F1674. Tie rods and clamp assemblies shall be wrapped in Denso paste and Tape (to manufacturer's specifications) or approved equal.

441.07.24 Hydrostatic Testing

441.07.24.01 General

Subsection 441.07.24.01 amended with the addition of the following:

Hydrostatic testing shall be conducted under the supervision of the Water Operator.

The Contractor shall assume all responsibility when testing against existing or new line valves. The Contractor is to provide all bulkheads, taps, fittings and pipe thrust restraint necessary to undertake pre-qualification or final testing. No hydrostatic testing against existing or new line valves will be undertaken satisfactory bacteriological results are received for the new portion of main being commissioned.

The Contractor is to provide means of obtaining water. Test section shall be filled slowly with water making sure that all air is removed from pipeline.

441.07.25 Flushing and Disinfecting Watermains

Subsection 441.07.25 is deleted and replaced with the following:

Flushing and disinfecting watermains shall be conducted under the direction and supervision of the Water Operator and the Contract Administrator. The Water Operator and the Contract Administrator shall be notified at least four days in advance of the proposed date on which such operations are to commence.

The Contractor shall submit a written plan of the proposed cleaning, flushing and disinfection procedure to the Contract Administrator for approval minimum two (2) weeks prior to the operation.

Watermains shall be cleaned, flushed, hydrostatically tested and disinfected in a sequence approved by the Contract Administrator. The Contract Administrator may permit or require the flushing and disinfecting to be carried out in stages as sections of the system are completed. Flushed sections shall be protected from contamination.

Watermains shall be cleaned and flushed before hydrostatic testing and disinfection is done.

Location of discharge points for flushing and disinfection of watermains shall be approved by the Water Operator and the Contract Administrator prior to the work.

The Contractor shall supply all labour and materials necessary for the cleaning, flushing and disinfection of the pipe.

Cleaning and Flushing of Watermains

All watermains shall be cleaned by the use of a minimum of four (4) swabs introduced at special entry sections or as directed by the Water Operator and forced by water pressure through the main to exit points approved by the Water Operator and the Contract Administrator. Cleaning shall be repeated until 2 consecutive swabs exhibit no discoloration and the discharge water is clear and approved by the Water Operator.

All swabs must be open cell polyurethane foam, having a density of 24 kilograms per cubic meter. The diameter of the swab shall be 1.25 times the outside for pipe diameters up to and including 300mm and 1.50 times the outside for pipe diameters greater than 300mm. The length of the swab shall be 2 times the pipe diameter.

Disinfection of Watermains

The main shall be disinfected according to instructions listed in the Ontario Ministry of Environment, Conservation and Parks, Watermain Disinfection Procedure. Where the procedure references AWWA C651, the most current version of the Standard shall be followed.

AWWA C651 Sections 4.3.9 Backflow Protection and 4.6 Final Connections to Existing Mains are required and are not optional. The Contractor shall use a certified backflow device provided by the Water Operator.

After flushing is completed, water from the existing distribution system shall be allowed to flow at a controlled rate into the new pipeline. Liquid chlorine solution shall be introduced so that the chlorine is distributed throughout the section being disinfected. The chlorine shall be applied so that the chlorine concentration is 50 mg/litre minimum throughout the section. The system shall be left charged with the chlorine solution for 24 hours.

Sampling and testing for chlorine residual shall be carried out by the Water Operator. The chlorine residual shall be tested in the section after 24 hours. If tests indicate a chlorine residual of greater than 60% of the initial dosage remaining (30 mg/litre minimum), the section shall be flushed completely and recharged with water normal to the operation of the system. If the test does not meet the requirements, the chlorination procedure shall be repeated until satisfactory results are obtained.

Following a minimum 16 hour rest period after the system has been recharged, the Water Operator shall take samples for bacteriological tests. Two sets of samples shall be collected at each sampling location, a minimum of 15 minutes apart while the sampling taps are left running. Samples shall be collected from every 350m of the new watermain plus one sample from the end of each of the line and at least one sample from each branch. The samples shall be submitted to an accredited laboratory and analyzed for E. coli, Total Coliform, and Heterotrophic Plant Count (HPC) bacteria. If there is any indication of contamination with E.coli within any sample taken, the disinfection procedure shall be repeated. If there is any indication of contamination with Total Coliforms or HPC count of > 500 CFU/mL, the watermain shall be flushed and HPC and coliform sampling repeated. If resample results are unsatisfactory, the disinfection procedure shall be repeated.

The new watermain will not be connected to the distribution system until all samples show the absence of Total Coliform and E. Coli and a HPC of less than 500 CFU/mL. Once all sampling is to the satisfaction of the Operating Authority, clearance will be given to connect to the distribution system.

The system shall not be put into operation until approval has been given by the Contract Administrator. It should be noted that only a Water Operator may operate the valve to put the new system into operation. All services shall be flushed as part of placing the line into service. All final connections shall be one pipe length and witnessed by a Water Operator.

The Contractor shall not make any claims for delays associated with awaiting test results.

441.07.27 Management of Excess Material

Subsection 441.07.27 is amended with the addition of the following:

Acceptable means of disposal are by discharge to storm sewer or open environment (drainage ditch or receiving water) with a free chlorine residual of 0.0 mg/L (i.e. no detectable level of chlorine).

Discharge of chlorinated water directly to sanitary sewer will not be permitted.

When discharging to the open environment or storm sewer, the contractor shall ensure the effectiveness of the dechlorination process. The Contractor shall provide a written plan for the dechlorination process which is to be submitted to the Contract Administrator and approved.

At a minimum the plan shall include:

- i) The chemical proposed to be used to dechlorinate, the proposed equipment and methodology for dechlorination, the proposed point of discharge and the receiving body (i.e. storm sewer, open environment, ditch, drain, water course).
- ii) The process proposed and how it will ensure adequate dosing and mixing of the dechlorination compound prior to discharge.
- iii) The measures in place to prevent erosion at the point of discharge and downstream.
- iv) The method and location of monitoring to ensure no chlorine residual remains downstream of the point of discharge.

Adequate mixing and dosage of the chemical with chlorinated water must be ensured.

The contractor shall document the dechlorination and monitoring process. These records shall be made available to the Water Operator upon request.

OPSS.MUNI 493 CONSTRUCTION SPECIFICATION FOR TEMPORARY POTABLE WATER SUPPLY SERVICES

493.04 Design and Submission Requirements

493.04.01 Submission Requirements

The following text is added preceding paragraph 1:

A temporary potable water supply sketch may be supplied by the Contract Administrator during the tender process. The intent of this sketch is to show the general layout and sizing of the system and is to be used as a guiding document only in preparation of the Temporary Potable Water Supply Service Plan.

OPSS.MUNI 510 CONSTRUCTION SPECIFICATION FOR REMOVAL

510.10 Basis of Payment

510.10.01 Removal of Item

Paragraph 2 of Subsection 510.10.01 is deleted and replaced with the following:

Imported Granular B, Type I, II or III backfill shall be included in the tender item for the removal specified in Contract Documents.

SUPPLEMENTAL SPECIFICATIONS – WATER

Part 2 SUPPLEMENTAL SPECIFICATIONS FOR WATER

2.1 Materials

All material used in the construction of the water distribution system that is in contact with the water shall be conforming to NSF 60, 61 and 372.

2.2 Tapping Sleeves and Valves

Tapping valves shall be according to AWWA C500.

Tapping sleeves and valves shall be supplied and installed by the Contractor. All tapping of commissioned watermains shall be completed by a Water Operator.

Tapping of watermain that has not been commissioned is permitted. All tapping must be undertaken by competent workmen equipped with tapping machines and other required equipment satisfactory to the Contract Administrator.

All tapping valves shall open by operating in a clockwise direction.

Size on size taps are not permitted unless otherwise specified in the Contract Documents. The diameter of the connection must be at least one size smaller than the diameter of the watermain to be tapped.

2.3 Corrosion Protection

Corrosion Protection shall be according to OPSS.MUNI 442.

All cast iron (CI) and ductile Iron (DI) fittings must be installed with a high purity magnesium anode in accordance with Standard Drawing W-20. Anode must be attached to fitting using a CADWELD and coated with mastic (Handy Cap IP or approved equal).

Epoxy coated gate valves do not require anodes.

Following installation, anodes shall be saturated with water to ensure immediate operation.

Connections to steel mains shall be electrically insulated. Materials used to electrically insulate steel mains shall be installed in accordance with the manufacturer's recommendations.

All flanges, nuts, bolts and washers shall be protected from corrosion by using Denso paste, profiling mastic and petrolatum tape (or approved equal).

Petrolatum tape systems shall be comprised of three components; paste, mastic and tape and meet the requirements of AWWA C217. Mastic must contain polystyrene beads and paste and tape must be of the same manufacturer as mastic to ensure compatibility. The three components provided shall be manufactured under ISO 9001 standards to ensure consistency of quality of products and substantiating documentation is to be provided upon request.

2.4 Thermal Insulation

Thermal insulation for watermains shall be extruded expanded polystyrene boards according to the requirements of CAN/ULC S701 with a minimum compressive strength of 690 kPa. The minimum thickness for thermal insulation shall be 50 mm.

Thermal insulation shall be provided at all locations where the depth of cover over the watermain is less than 1.7 meters.

Thermal insulation shall be provided at all locations where the separation from the watermain to a sewer, sewer structure or culvert is less than 0.6 meters.

Thermal insulation shall extend a minimum of 0.6 meters on each side of the watermain.

Measurement and payment for Thermal Insulation shall be in square metres and shall be full compensation for all labour, equipment and materials required to carry out the work.

2.5 Tracer Wire

Tracer wire shall be installed on all non-metallic watermains, hydrants laterals and water services except where such water service pipe is of copper material. The wire shall be installed in such a manner as to be able to properly trace all watermains, hydrant laterals and water services without loss or deterioration of signal or without the transmitted signal migrating off the tracer wire.

Tracing wire for watermain installed by open cut method shall be #12 AWG single strand, high strength copper-clad steel with 30mil of blue HDPE insulation in accordance with ASTM-D-1248, specifically manufactured for direct burial applications and shall have a minimum break load tensile strength of at least 200 kg (450 lbs). Tracer wire for installation by directional drilling shall have a minimum break load tensile strength of at least 520 kg (1150 lbs).

Except for approved spliced in connections, tracer wire shall be continuous and without splices from valve to valve, valve to fire hydrant or fire hydrant to fire hydrant. Joints in the wire between valves and/or hydrants will not be permitted.

At each valve a loop of wire shall be brought up inside the valve box at the top of the box below the top of the valve cover in accordance with Standard Drawing W-09.

At each hydrant, tracer wire shall be brought up into a tracer wire access point and connected to the terminal. A minimum of 1.0m slack in the tracer wire shall be provided in the tracer wire access point. Tracer wire access points shall be blue in color with a minimum of two terminals and shall be flange mounted (Copperhead Industries Cobra Access Point or approved equivalent).

At each water service, tracer wire shall be connected to both the main stop and the curb stop with an approved electrical thaw nut connector.

All splices or repaired wire connections in the tracer wire system shall be made using waterproof connectors specifically rated for underground applications.

At the point of connection between cast iron or ductile iron watermains, with any non iron watermain, the tracer wire shall be properly connected to the iron pipe with a thermite weld or approved equivalent. All tracer wire welds onto existing cast or ductile iron pipe shall be completely sealed with the use of an approved mastic type sealer specifically manufactured for underground use and shall be protected from contamination by the backfill material with the use of a plastic membrane. As an alternative, approved equivalent prefabricated assemblies (Chace/Royston Handy Cap IP or approved equal) may be used. In all cases, the pipe is to be properly cleaned and material applications shall be according to the manufacturer's instructions.

For watermains, hydrant laterals and water services installed by horizontal directional drilling, two (2) tracer wires shall be installed simultaneously with the pipe.

Tracer wire shall be installed along the top of the pipe and securely affixed to the pipe at six (6) meter intervals. At water service saddles, the tracer wire shall not be allowed to be placed between the saddle and the watermain.

The wire shall be protected from damage during the execution of the work. No breaks or cuts in the tracer wire or tracer wire insulation shall be permitted. The Owner shall test the tracer wire for conductivity immediately following installation and prior to final acceptance. If the tracer wire is not continuous from valve to valve, the Contractor shall, at his expense, replace or repair the wire.

2.6 Drinking Water Quality Management System (DWQMS)

Prior to construction on a Water System, the Contractor will be required to provide a signed copy of the DWQMS Operational Form "New Construction Sign-Off Form" to the Contract Administrator. All work affecting any Water System must be completed in accordance with the Owner's DWQMS requirements.

SUPPLEMENTAL SPECIFICATIONS – WATER

Part 3 STANDARD DRAWINGS FOR WATER

DIAMETER OF MAIN Ø (mm)	MINIMUM No. OF STEEL RODS	MINIMUM LENGTH TO BE RESTRAINED ON EACH SIDE OF FITTINGS (m)				
		11.25°	22.5°	45°	90°	DEAD END
100	2	4.0	4.0	4.0	4.0	20
150	2	4.0	4.0	4.0	5.5	20
200	2	4.0	4.0	4.0	7.0	20
250	4	4.0	4.0	4.0	8.5	30
300	4	4.0	4.0	4.0	10.0	30

THRUST RESTRAINT CHART

NOTES:

1. STEEL RODS ARE TO BE MINIMUM OF 20MM IN DIAMETER.
2. IF ANY JOINT IS ENCOUNTERED IN THE ABOVE RESTRAINED LENGTH IT MUST BE RESTRAINED.
3. 5° BENDS (BELL & SPIGOT FITTING) MUST BE RESTRAINED AT JOINTS.
4. ALL VALVES SHALL BE TREATED AS DEAD END WATERMAINS AND SHALL BE RESTRAINED ACCORDINGLY.
5. ALL RESTRAINT ASSEMBLIES SHALL BE PROTECTED WITH DENSO TAPE AND PASTE AND CATHODIC PROTECTION AS PER W-20
6. REDUCERS SHALL BE RESTRAINED ON BOTH SIDES FOR:
 LARGE ϕ^1 - SMALL ϕ^2 OF THE LENGTH REQUIREMENT FOR A LARGE ϕ DEAD END.
 LARGE ϕ^2

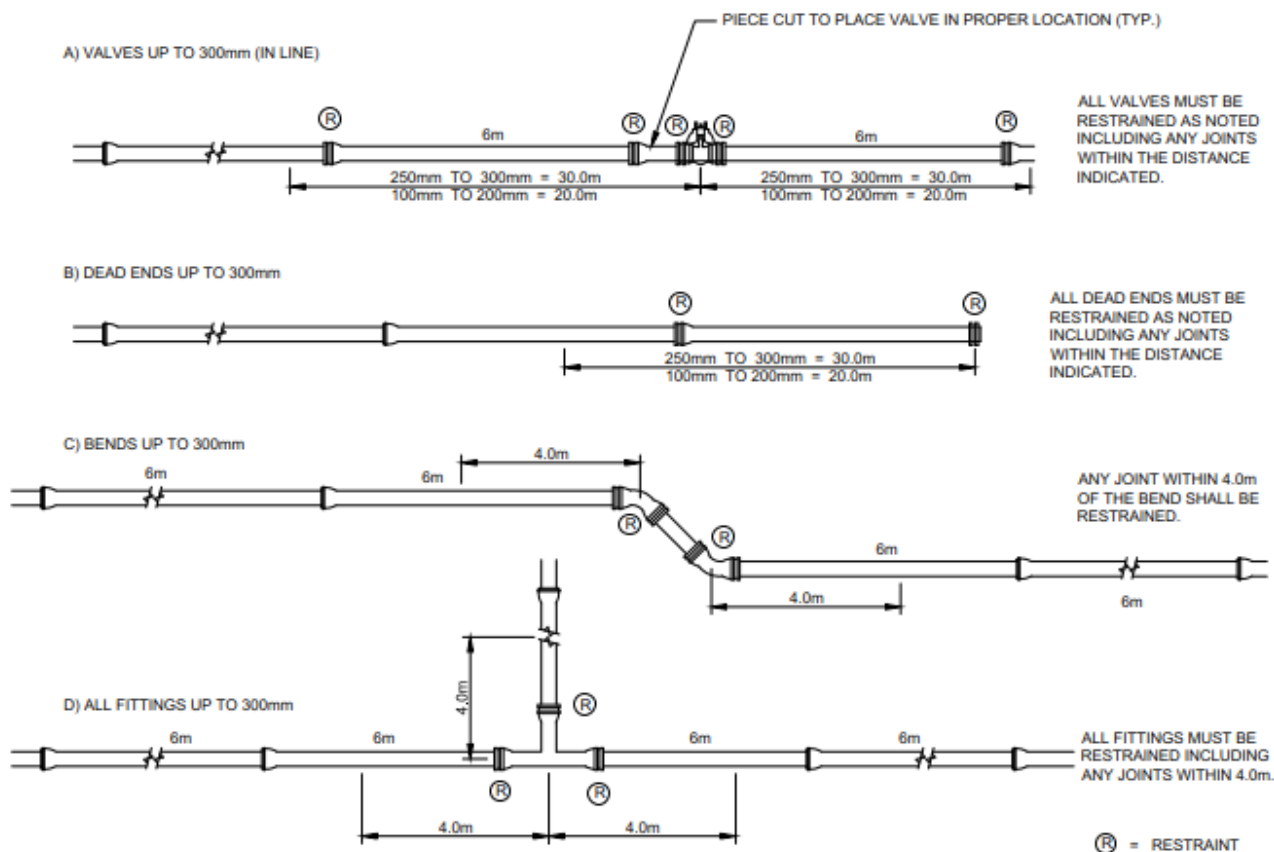

THRUST RESTRAINT DETAILS

NOT TO SCALE
 ALL DIMENSIONS IN MILLIMETERS UNLESS OTHERWISE NOTED

STANDARD DRAWING

THRUST RESTRAINT FOR WATERMAIN UP TO AND INCLUDING 300mm Ø

REVISION DATE: 26 NOV 2021
 DRAWING #: W-01

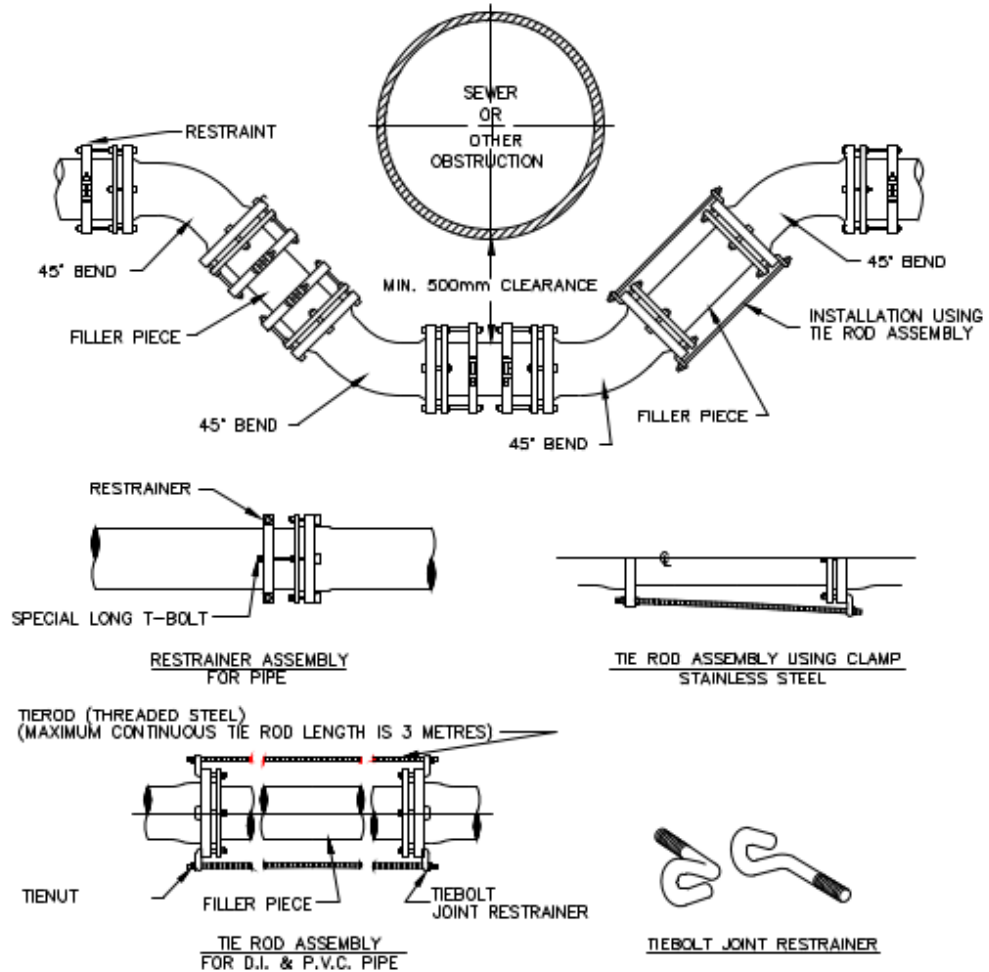

NOTES:

1. Grip Rings may be used for thrust restraint.
2. Cover tie bolt assembly with denso paste and denso tape.
3. Each restraint assembly is to be protected with an anode.

NOT TO SCALE
ALL DIMENSIONS IN MILLIMETERS UNLESS OTHERWISE NOTED

STANDARD DRAWING

TYPICAL OFFSET WATERMAIN

REVISION DATE: 26 NOV 2021
DRAWING #: **W-02**

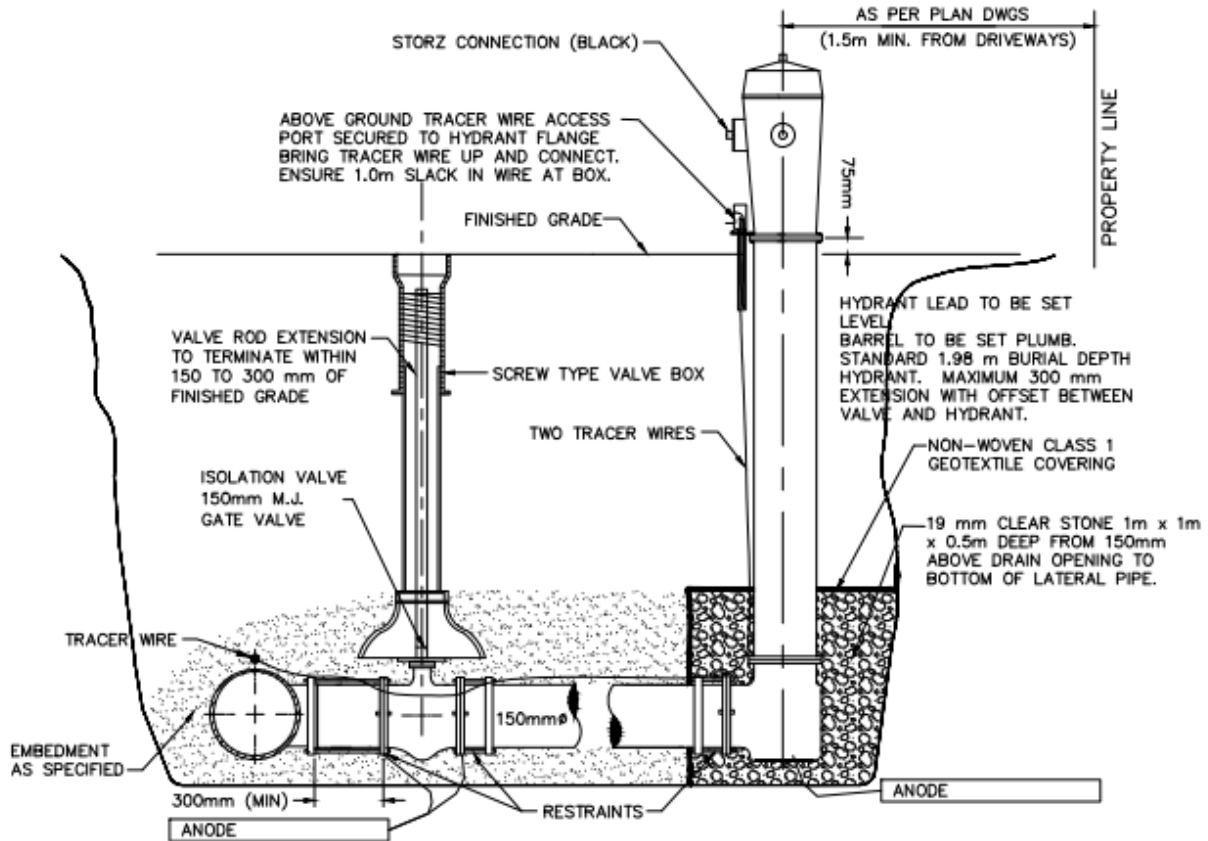

NOTES:

1. REFER TO SPECIFICATIONS REGARDING TRACER WIRE.
2. HYDRANT TO BE SELF DRAINING.
3. HYDRANT VALVE TO BE LOCATED AS REFERENCED ON CONTRACT DRAWINGS OR AS SPECIFIED IN FIELD.
4. ANODES SHALL BE APPLIED TO D.I. OR C.I. FITTINGS INCLUDING HYDRANT BOOT AND RESTRAINT DEVICES.

NOT TO SCALE
ALL DIMENSIONS IN MILLIMETERS UNLESS OTHERWISE NOTED

STANDARD DRAWING

**FIRE HYDRANT
AND VALVE BOX DETAIL**

REVISION DATE: 26 NOV 2021
DRAWING #: **W-03**

EXISTING SERVICE NOMINAL SIZE	PEX TUBING SIZE EQUIVALENTS	
	PEX TUBING	SADDLE SIZE / MAIN STOP / CURB STOP
19 mm	25 mm	25 mm
25 mm	25 mm	25 mm
38 mm	50 mm	50 mm
50 mm	50 mm	50 mm

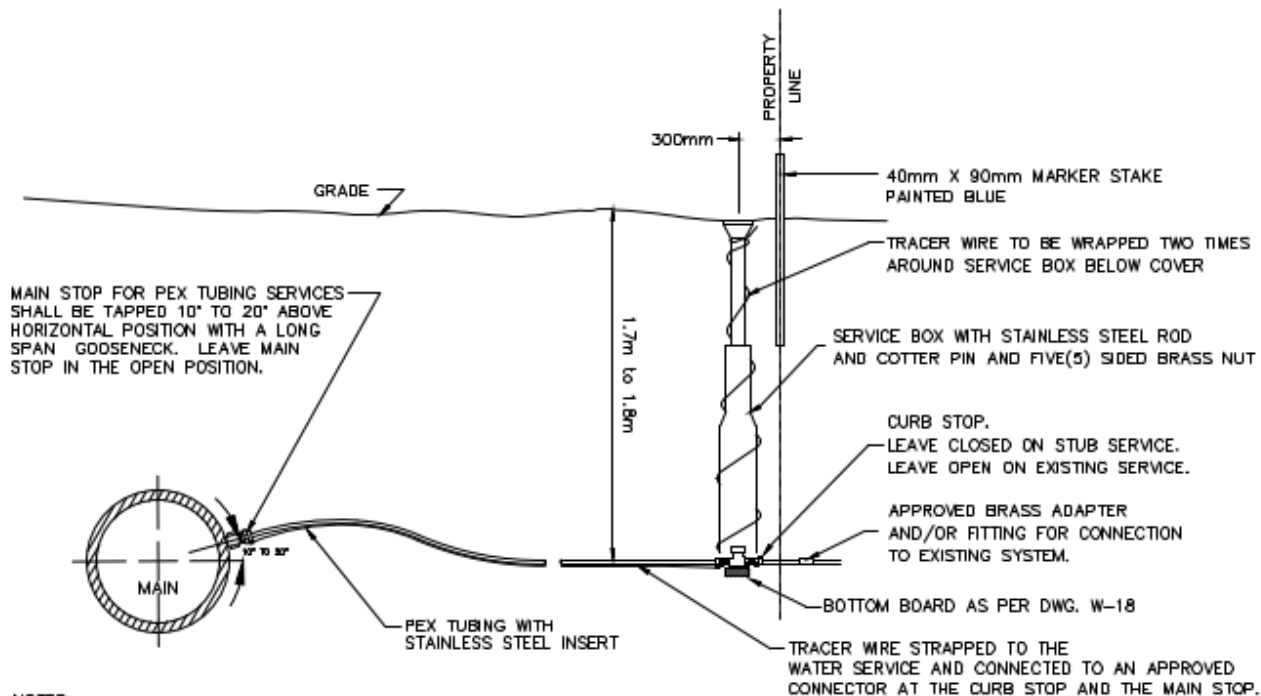

1. ALL SERVICES 38 mm Ø AND LARGER SHALL HAVE A 50 mm SQUARE NUT AND LARGE SCREW TYPE VALVE BOX WITH BUBBA BASE.
2. MINIMUM SIZE OF PEX TUBING IS 25 mm Ø.
3. ALL PVC WATERMAIN AND ANY 100 mm Ø METAL WATER MAIN SHALL HAVE A SERVICE SADDLE.
4. ANY METAL WATERMAIN 150 mm Ø AND LARGER MAY BE DIRECT TAPPED FOR 25 mm Ø WATER SERVICES .
5. ALL WATER SERVICES LARGER THAN 25 mm Ø REQUIRE A SERVICE SADDLE TO BE INSTALLED PRIOR TO TAPPING THE WATERMAIN.
6. NO COUPLING CONNECTIONS OF WATER SERVICE ARE PERMITTED WITHIN THE ROAD ALLOWANCE.
7. ANODES SHALL BE INSTALLED ON ALL EXISTING COPPER SERVICES ENCOUNTERED

NOT TO SCALE
ALL DIMENSIONS IN MILLIMETERS UNLESS OTHERWISE NOTED

STANDARD DRAWING

**WATERMAIN
SERVICE INSTALLATION**

REVISION DATE: 26 NOV 2021
DRAWING #: **W-04**

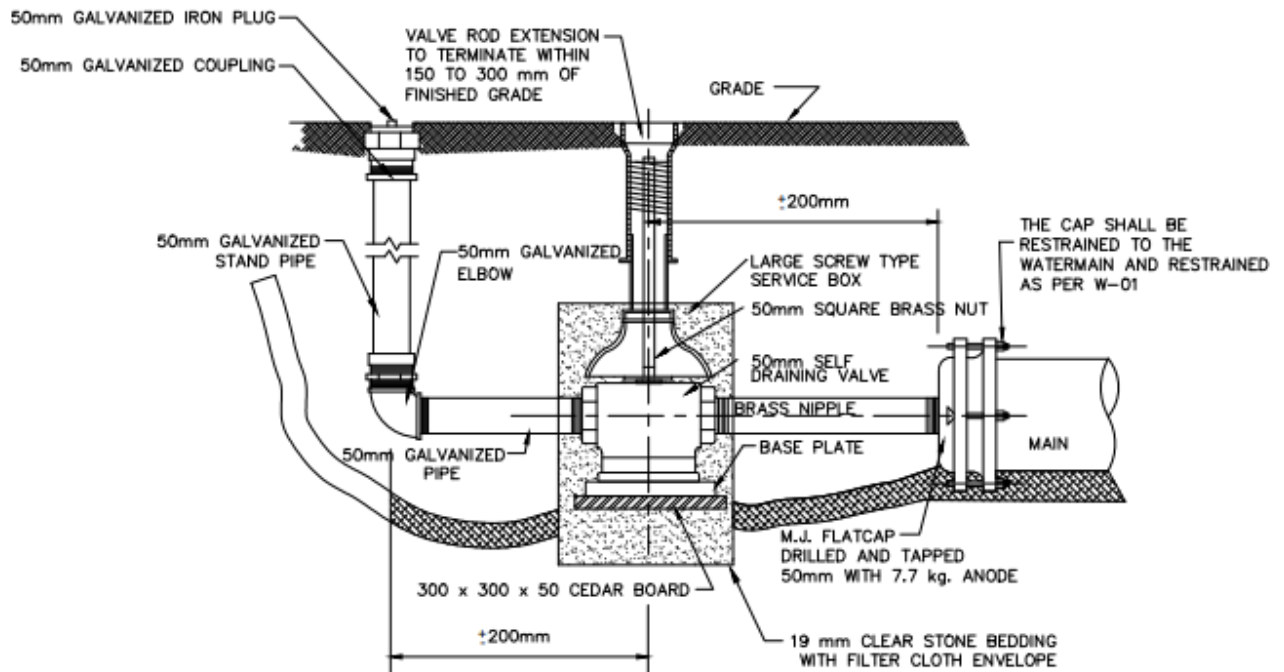

NOTE:
LOWER VALVE BOX BASE SHALL BE NOTCHED TO ACCOMODATE
PIPE AND BOX SHALL BE SEATED ON BASE PLATE.

NOT TO SCALE
ALL DIMENSIONS IN MILLIMETERS UNLESS OTHERWISE NOTED

STANDARD DRAWING

**STANDARD 50mm
BLOW - OFF**

REVISION DATE: 26 NOV 2021
DRAWING #: **W-06**

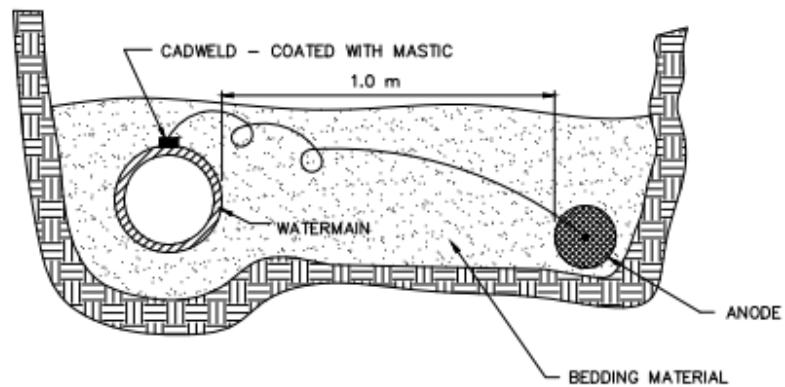

NOTES:

1. ANODES SHALL BE IN ACCORDANCE WITH CITY OF ST. THOMAS STANDARD DRAWING W-20
2. BEDDING MATERIAL IS TO BE AS SPECIFIED IN THE CONTRACT DOCUMENTS.
3. ANODES SHALL BE SATURATED WITH WATER PRIOR TO BACKFILL.

NOT TO SCALE
 ALL DIMENSIONS IN MILLIMETERS UNLESS OTHERWISE NOTED

STANDARD DRAWING

**MAGNESIUM ANODE
 INSTALLATION**

REVISION DATE: 26 NOV 2021
 DRAWING #: **W-07**

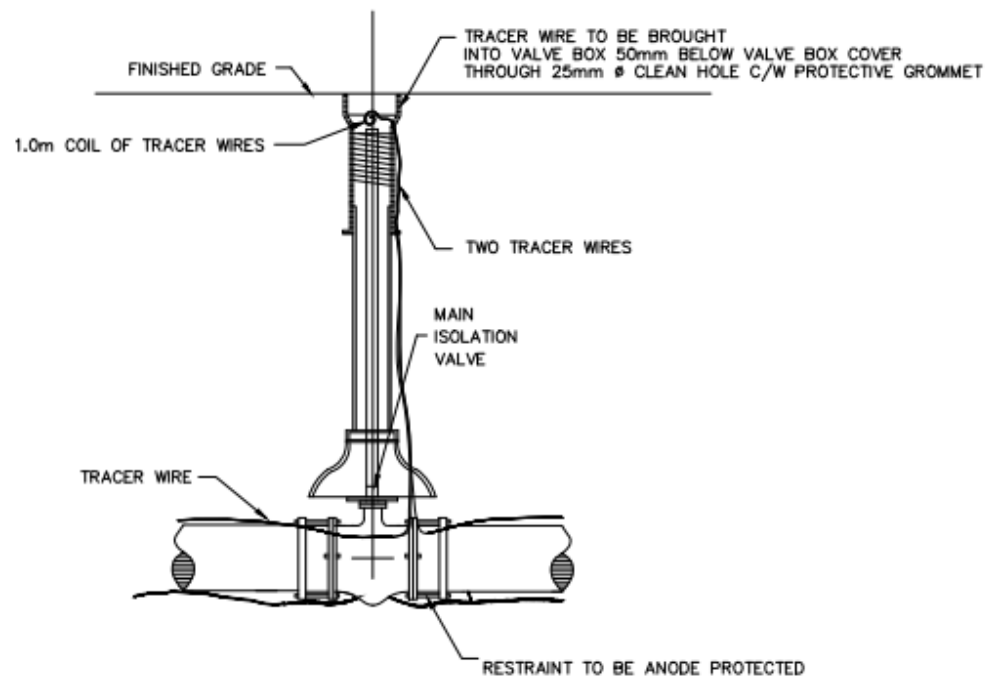

SCREW TYPE VALVE BOX

NOT TO SCALE
ALL DIMENSIONS IN MILLIMETERS UNLESS OTHERWISE NOTED

STANDARD DRAWING

TRACER WIRE CONNECTION

REVISION DATE: 26 NOV 2021
DRAWING #: **W-09**

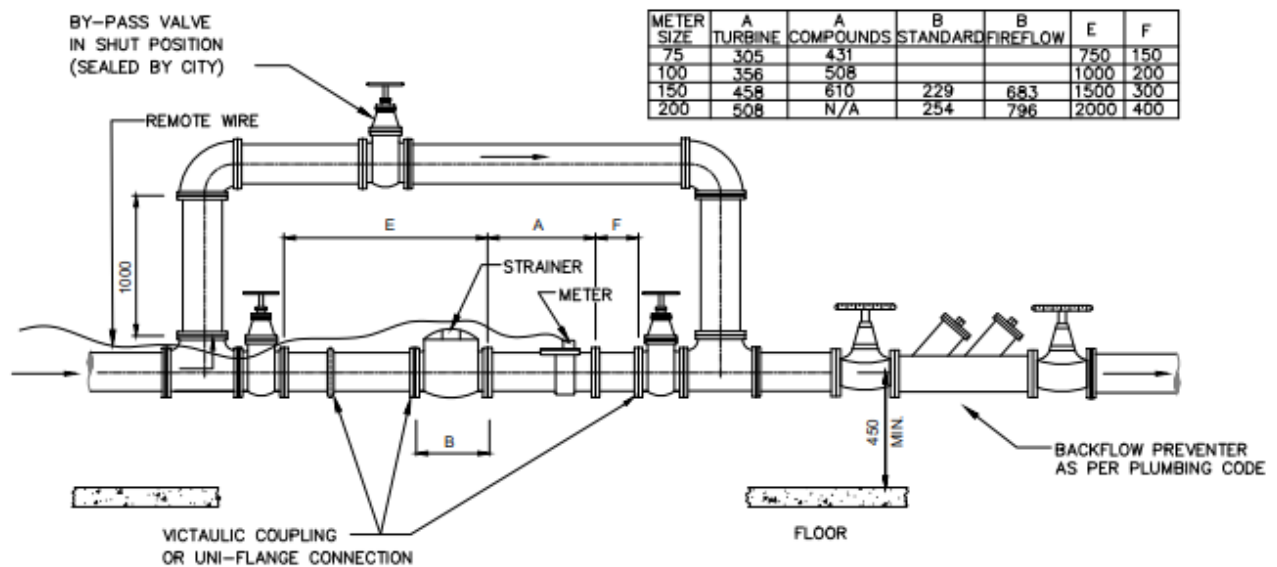

NOTES:

1. All dimensions are in mm unless otherwise shown.
2. Flanged fittings are required for all meters.
3. Minimum size of valving and by-pass piping to be equal to meter size.
4. All check valves, back flow prevention, pressure reducing valves, etc. must be installed after the by-pass when fire flows are metered.
5. All meters are to be installed horizontally unless approved otherwise by the City.
6. Installation indicates the minimum space requirements in a mechanical or meter room. Minimum clearance from floor, wall or fixed equipment to be 450mm.

NOT TO SCALE
ALL DIMENSIONS IN MILLIMETERS UNLESS OTHERWISE NOTED

STANDARD DRAWING

**TYPICAL TURBINE WATER METER
INSTALLATION FOR 75mm TO 200mm**

REVISION DATE: 26 NOV 2021
DRAWING #: **W-13**

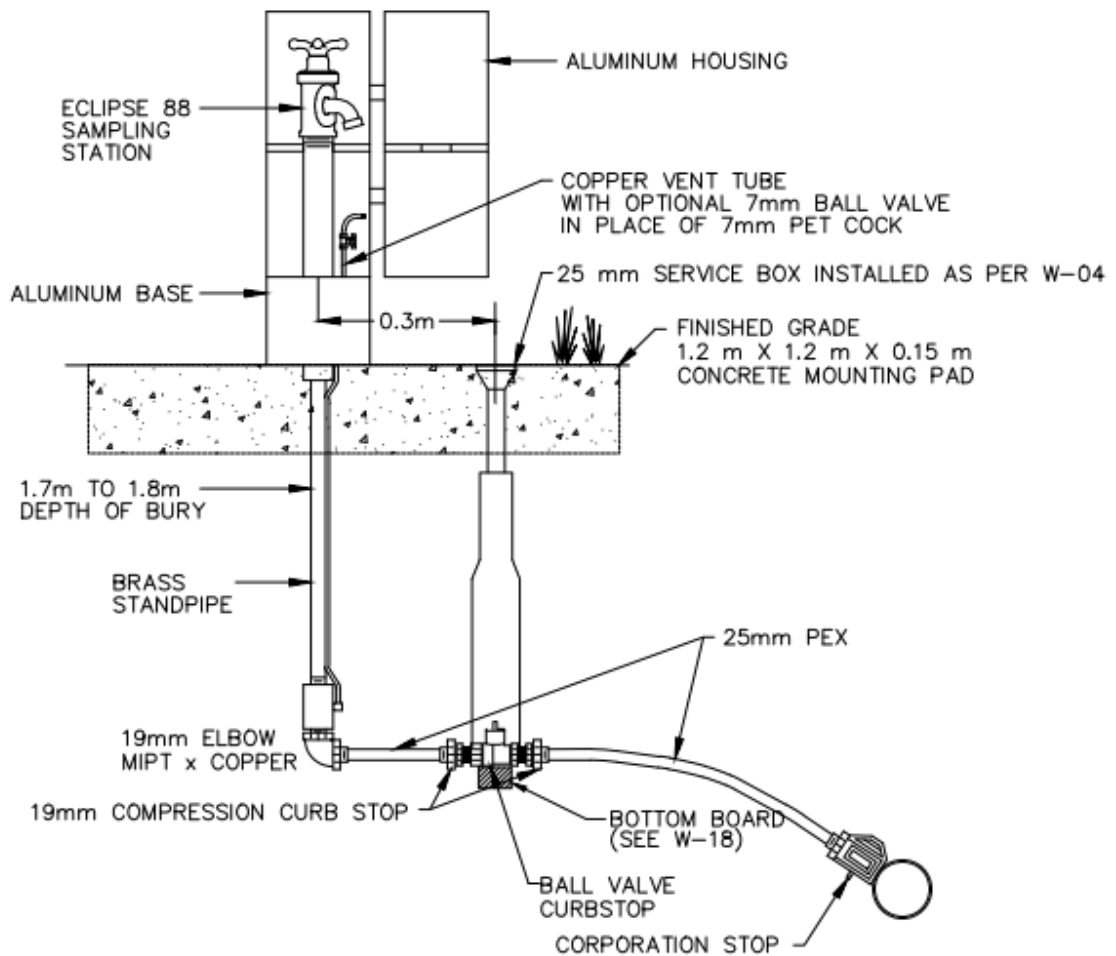

NOTES

1. SAMPLING STATIONS SHALL BE 1.70m (MIN) DEPTH, WITH A 25mm FIP INLET, AND A (25mm HOSE OR UNTHREADED) NOZZLE.
2. ALL STATIONS SHALL BE ENCLOSED IN A LOCKABLE, NON-REMOVABLE, ALUMINUM-CAST HOUSING.
3. WHEN OPENED, THE STATION SHALL REQUIRE NO KEY FOR OPERATION, AND THE WATER WILL FLOW IN AN ALL BRASS WATERWAY
4. ALL WORKING PARTS WILL ALSO BE OF BRASS AND BE REMOVABLE FROM ABOVE GROUND WITH NO DIGGING. EXTERIOR PIPING SHALL BE BRASS PIPE.
5. A COPPER VENT TUBE WILL ENABLE EACH STATION TO BE PUMPED FREE OF STANDING WATER TO PREVENT FREEZING AND TO MINIMIZE BACTERIA GROWTH.
6. ECLIPSE NO. 88 PEDESTAL TYPE SAMPLING STATION SHALL BE MANUFACTURED BY KUPFERLE FOUNDRY, ST. LOUIS, MO 63102

NOT TO SCALE
ALL DIMENSIONS IN MILLIMETERS UNLESS OTHERWISE NOTED

STANDARD DRAWING

**WATER SAMPLING
STATION DETAIL**

REVISION DATE: 26 NOV 2021
DRAWING #: **W-17**

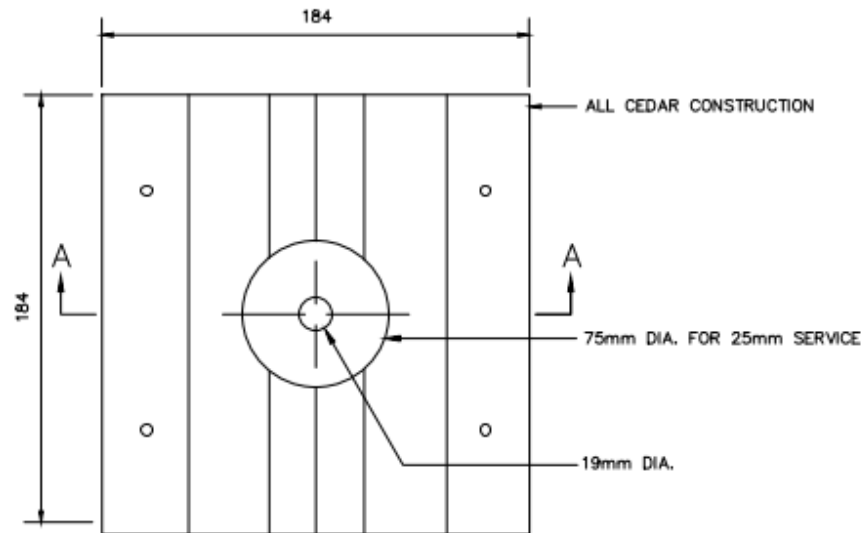

PLAN VIEW

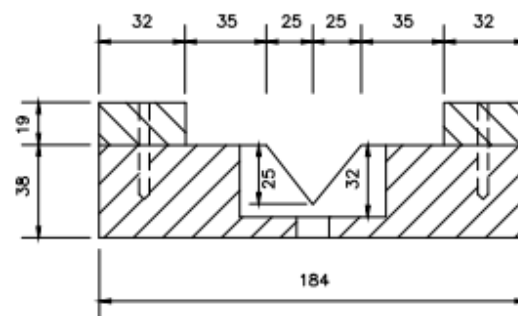

SECTION "A-A"

NOT TO SCALE
ALL DIMENSIONS IN MILLIMETERS UNLESS OTHERWISE NOTED

STANDARD DRAWING

**BOTTOM BOARD
FOR STANDARD WATER SERVICES**

REVISION DATE: 26 NOV 2021
DRAWING #: **W-18**

W-20 Magnesium Anode Configuration for Various Metallic Fittings

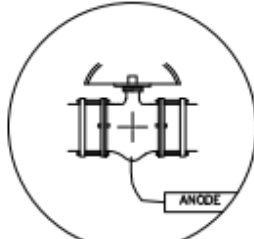

7.7 kg ANODE FOR EACH VALVE WITH RESTRAINT ASSEMBLY

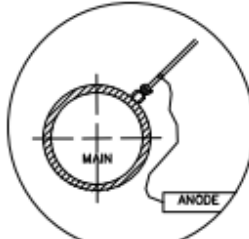

2.7 kg ANODE CLAMPED TO EACH COPPER WATER SERVICE



7.7 kg ANODE FOR EACH TAPPING SLEEVE AND VALVE WITH RESTRAINT ASSEMBLY OVER 80 mm Ø, ALL OTHERS TO BE PROTECTED WITH A 2.7 kg ANODE.

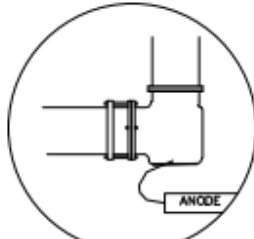

7.7 kg ANODE FOR EACH HYDRANT WITH RESTRAINT ASSEMBLY

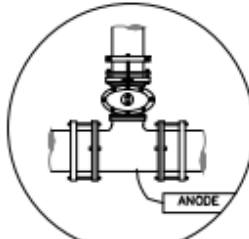

7.7 kg ANODE FOR EACH ANCHOR TEE AND VALVE WITH RESTRAINT ASSEMBLY

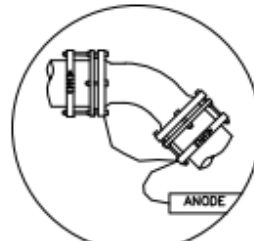

BENDS AND REDUCERS ARE TO BE PROTECTED WITH ONE (1) 7.7kg ANODE WITH JUMPER CABLE OR TWO (2) 2.7 kg ANODES CONNECTED INDIVIDUALLY. AN M.J. FITTING WITH RESTRAINTS REQUIRES ONE (1) 7.7 kg ANODE.

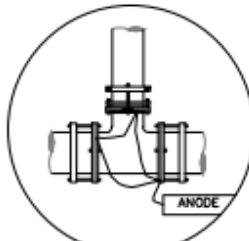

7.7 kg ANODE WITH JUMPER CONNECTIONS TO EACH OF THE THREE (3) RESTRAINTS ON THE PVC TEE OR CONNECTED DIRECTLY TO THE M.J. TEE. THE SAME APPLICATION APPLIES TO THE FOUR (4) RESTRAINTS ON A CROSS.

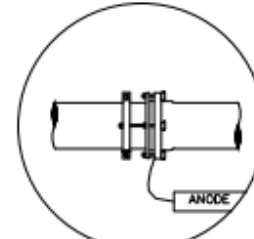

2.7 kg ANODE PER RESTRAINT OR ONE (1) 7.7 kg ANODE FOR THREE (3) RESTRAINTS IF WITHIN 3.0 m.

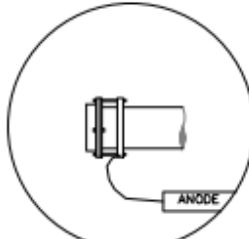

7.7 kg ANODE FOR A RESTRAINT ON A CAP OR A PLUG AT A DEAD END

NOTES

- 1) ALL ANODE CONNECTIONS SHALL BE CADWELD CONNECTIONS UNLESS STATED OTHERWISE.
- 2) ALL JUMPER CONNECTIONS SHALL BE MADE WITH A MINIMUM #10 GAUGE RWU90 WIRE.
- 3) FOR UNUSUAL CONFIGURATIONS THE CITY ENGINEER OR HIS DESIGNATE SHALL DETERMINE THE CATHODIC PROTECTION REQUIREMENTS.

NOT TO SCALE
ALL DIMENSIONS IN MILLIMETERS UNLESS OTHERWISE NOTED

STANDARD DRAWING

MAGNESIUM ANODE CONFIGURATION FOR VARIOUS METALIC FITTINGS

REVISION DATE: 26 NOV 2021
DRAWING #: **W-20**



SUPPLEMENTAL SPECIFICATIONS ROADS

SUPPLEMENTAL SPECIFICATIONS - ROADS

Part 1 AMMENDMENTS TO ONTARIO PROVINCIAL STANDARDS FOR ROADS AND PUBLIC WORKS

OPSS 102 GENERAL SPECIFICATION FOR MATERIAL WEIGHING

102.07 CONSTRUCTION – WEIGHING

102.07.01.01 Mass Measurement

Subsection 102.07.01.01 is deleted in its entirety and replaced by the following:

Mass measurements will be made at weigh scales equipped with an automatic printing device capable of producing tickets. Mass measurement of all granular and asphalt material shall be electronically transmitted from the platform weight sensing device to the computer, with a direct cable connection. Any form of manual override, except total transaction rejection, will not be allowed.

Tickets of laser quality type shall be produced electronically, using black print only, on a printing device connected by direct cable connection to the computer, capable of producing tickets conforming to the Owner's requirements. Tickets shall be supplied by the contractor and shall indicate the truck number, type of material, gross weight, net weight, tare weight and contract number.

Hand written tickets will not be accepted.

OPSS.MUNI 180 GENERAL SPECIFICATION FOR THE MANAGEMENT OF EXCESS MATERIAL

180.01 SCOPE

Subsection 180.01 is amended by the addition of the following:

Amendments to OPSS.MUNI 180 shall apply to sewer, water, electrical work and all other work required for the project.

180.07.01 Conditions on Management of Excess Material – General

Paragraph 3 of Subsection 180.07.01 is deleted and replaced with the following:

When excess material includes asbestos waste, the asbestos waste shall be managed in accordance to Section 17 of O. Reg. 347 under the Environmental Protection Act, latest revision.

The Contractor shall submit to the Contract Administrator prior to the work a plan in writing for the handling, management and disposal of asbestos waste.

OPSS.MUNI 201 CONSTRUCTION SPECIFICATION FOR CLEARING, CLOSE CUT CLEARING, GRUBBING, AND REMOVAL OF SURFACE AND PILED BOULDERS**201.07 CONSTRUCTION****201.07.01 General**

Subsection 201.07.01 is amended by the addition of following:

All tree removals shall be completed by a qualified Arborist or approved tree care professional and in accordance with good arboricultural practices.

OPSS.MUNI 206 CONSTRUCTION SPECIFICATION FOR GRADING**206.07 CONSTRUCTION****206.07.01.04 Tolerances - General**

Subsection 206.07.01.04 is amended by the addition of following:

Finished graded surfaces shall not be uniformly high or uniformly low.

206.07.03.01.03 Excavation Below Subgrade

Subsection 206.07.03.01.03 is deleted in its entirety and replaced by the following:

Unsuitable materials, other than swamp material, shall be removed below the subgrade to the lengths, widths, and depths specified in the Contract Documents, or as directed by the Contract Administrator. The resulting excavation shall be backfilled with approved material and compacted according to OPSS 501.

OPSS.MUNI 310 CONSTRUCTION SPECIFICATION FOR HOT MIX ASPHALT**310.07 CONSTRUCTION****310.07.05.02 Hot Mix Asphalt****310.07.05.02.01 General**

Subsection 310.07.05.02.01 is amended with the addition of the following:

Quality Assurance sampling and testing on behalf of the Owner will be performed by a qualified geotechnical consultant at a frequency determined by the Contract Administrator. The Contractor shall provide any assistance, materials, labour and equipment necessary to assist the geotechnical consultant in obtaining representative samples as required.

310.07.05.02.04 Cores

Subsection 310.07.05.02.04 is amended by the addition of the following:

The minimum thickness of the compacted hot mix layer(s) shall be as specified on the Contract Documents. The Owner may, at his option and expense, require the Contractor to obtain 100mm diameter cores of the compacted hot mix to verify the thickness of the asphalt layer(s). Holes made by the removal of such samples shall be filled with the specified hot mix and compacted.

If the average thickness of the base asphalt and/or surface asphalt varies by 15mm greater than or less than the specified hot mix thickness, the hot mix asphalt placed may be rejected. Rejected asphalt shall be removed and replaced as directed by the Contract Administrator.

310.07.08 Widening and Irregular Sections

Subsection 310.07.08 (a) is amended with the addition of the following:

Stepped joints are required unless otherwise specified in the Contract Documents.

310.07.11 Longitudinal and Transverse Joints

310.07.11.01 General

Subsection 310.07.11.01 is amended with the addition of the following:

Stepped joints are required for all full depth longitudinal and transverse joints in the roadway and at commercial and industrial driveways.

When matching new asphalt to existing asphalt, ensure that all joints will not be located in the vehicular running tracks and that any cut areas can be restored with conventional paving equipment and rollers. All cuts shall be squared off to avoid any hand placed areas.

310.07.14 Surface Appearance

Subsection 310.07.14 is amended by the addition of the following:

The repair to a defective surface course will be a minimum of at least one full lane width by a minimum length that is to be determined by the Contract Administrator.

310.08 QUALITY ASSURANCE

310.08.01 General

Subsection 310.08.01 is amended by the addition of the following:

Repairs to defective areas will be a minimum of at least one full lane width by a minimum length that is to be determined by the Contract Administrator.

310.10 BASIS OF PAYMENT**310.10.01 - Items**

Sub-section 310.10.01 is amended by the addition of the following:

OPSS 310 Appendix 310-B, Supplemental Requirements for Using the MTO Performance Graded Asphalt Cement (PGAC) Price Index in Municipal Contracts shall apply.

OPSS.MUNI 331 CONSTRUCTION SPECIFICATION FOR FULL DEPTH RECLAMATION WITH EXPANDED ASPHALT STABILIZATION**331.10 BASIS OF PAYMENT****331.10.01 Full-Depth Reclamation with Expanded Asphalt Stabilization - Item**

Subsection 331.10.01 is amended by the addition of the following:

OPSS 310 Appendix 310-B, Supplemental Requirements for Using the MTO Performance Graded Asphalt Cement (PGAC) Price Index in Municipal Contracts shall apply.

OPSS.MUNI 333 CONSTRUCTION SPECIFICATION FOR COLD IN-PLACE RECYCLING**333.10 BASIS OF PAYMENT****333.10.01 Cold In-Place Recycled Mix - Item**

Subsection 333.10.01 is amended by the addition of the following:

OPSS 310 Appendix 310-B, Supplemental Requirements for Using the MTO Performance Graded Asphalt Cement (PGAC) Price Index in Municipal Contracts shall apply.

OPSS 350 CONSTRUCTION SPECIFICATION FOR CONCRETE PAVEMENT AND CONCRETE BASE**350.05 MATERIALS****350.05.01 Concrete**

Paragraph a) of Subsection 350.05.01 is deleted in its entirety and replaced by the following:

- (a) The coarse aggregate for concrete pavement and concrete base shall have a gradation with a nominal maximum size of 19.0 mm aggregate and shall be according to the requirements of OPSS 1002.

350.07 CONSTRUCTION**350.07.02 Joints****350.07.02.01 General**

Paragraph 1 of Subsection 350.07.02.01 is deleted and replaced with the following:

The Contractor shall submit a joint layout for approval prior to placing either curb and gutter or concrete pavement or both. Joints shall be of the type and at the location as specified in the Contract Documents.

Subsection 350.07.02.01 is amended by the addition of the following:

Transverse joint layouts shall begin by planning joints to intercept roundouts for CB's and MH's. The centre line of road distance between ends shall be divided into panels with a maximum length of either 30 times the pavement thickness or 4.5m, whichever is less.

Transverse joints shall have a depth not less than 1/4 the slab thickness and be continuous through the curb.

Longitudinal joint spacing shall not exceed 3.8m. Sawn longitudinal joints should be cut to 1/3 the pavement thickness.

350.07.02.04 Position and Alignment Tolerances**350.07.02.04.02 Joints**

Subsection 350.07.02.04.02 Joints is deleted in its entirety and replaced by the following:

All joints shall be placed within a tolerance of +/-15mm from the design location shown on the saw cut construction drawing, or from some other location required by the Contract Administrator.

350.07.03.02 Finishing

Subsection 350.07.03.02 is amended by the addition of the following:

Following strike-off and consolidation, the concrete pavement shall be scraped with an aluminum or magnesium straight-edge, 3 meters wide, equipped with a handle to permit operation from the edge of pavement. Any excess water or latency shall be removed from the surface before scraping.

350.07.05 Joint Sealing

Subsection 350.07.05 is amended by the addition of the following:

Silicone sealant shall be used for joints in concrete pavement. Silicone shall be Dow Corning 888 or approved equivalent and shall be installed in accordance with the manufacturer's recommendations.

350.07.08 Sampling and/or Testing

350.07.08.01 Slump and Air Content

Subsection 350.07.08.01, first paragraph, is deleted in its entirety and replaced by the following:

Field sampling and testing of plastic concrete for conformance to surface tolerance, slump and air content shall be undertaken by the Owner.

350.07.08.02 Coring

Subsection 350.07.08.02 is deleted in its entirety and replaced by the following:

When required or directed by the Contract Administrator, coring shall be carried out when the concrete or lean concrete is 28 to 35 days old. The Contractor shall cut a core in the location(s) designated by the Contract Administrator. The core shall be 100 mm in diameter and shall be drilled through the complete depth of concrete pavement, concrete base or lean concrete base, perpendicular to the surface of the slab.

350.07.08.05 Transportation of Cores

Subsection 350.07.08.05 is deleted in its entirety and replaced with the following:

The concrete cores shall be delivered by the Contract Administrator to a laboratory designated by the Owner. The cores shall be delivered on the same day they were obtained.

350.08 QUALITY ASSURANCE

350.08.01 Acceptance Criteria for Strength and Thickness

Subsection 350.08.01.01 is deleted in its entirety and replaced by the following:

Slab thickness and core and/or cylinder compressive strength shall be the basis for acceptance of concrete pavement, concrete base and lean concrete bases.

When concrete cylinders are tested for compression, the compressive strengths will be calculated in accordance with CAN/CSA-A23.1-M90 Section 17.5.7 and CAN/CSA-A23.1-M90 section 17.5.7.1 and as follows:

- (1) With the standard deviation designated "s", these criteria can be expected to be met 99% of the time if the concrete is proportioned to produce an average strength as follows:
 - (a) 1.4 times the standard deviation (1.4 s) above the specified strength when the standard deviation (s) is not more than 3.5 MPa; and
 - (b) 2.4 times the standard deviation minus 3.5 MPa (2.5 - 3.5 MPa) above the specified strength when the standard deviation (s) is not more than 3.5 MPa.
- (2) The standard deviation used in Note 1 should be based on at least 30 consecutive strength tests, representing concrete whose design strength is within 7 MPa of that required for the work made with similar materials and under similar conditions to those expected.
- (3) Individual tests from concrete meeting these requirements can be expected to be below specified strength about 10% of the time.
- (4) For high-strength concrete different acceptance criteria will be specified by the Owner.

The strength level of each class of concrete shall be considered satisfactory if the averages of all sets of three consecutive strength tests for that class at one age equal or exceed the specified strength, and no individual strength test is more than 3.5 MPa below the specified strength. These requirements shall not apply to field-cured specimens.

350.08.01.03 Lot Size

350.08.01.03.01 Compressive Strength and Thickness

Paragraph 2 of Subsection 350.08.01.03.01 is deleted in its entirety and replaced with the following: Testing of compressive strength and thickness for each lot shall be conducted by the Owner at the locations and frequency as directed by the Contract Administrator.

350.08.01.05 Removal of Unacceptable Concrete

Subsection 350.08.01.05 is deleted and replaced with the following:

If the mean core compressive strength and/or deficiency in the thickness of the concrete pavement slab dictates removal or replacement, the Contractor will receive written instruction from the Contract Administrator to correct the deficient area(s).

The area to be removed shall be bounded by the nearest contraction joint and longitudinal joint or concrete pavement or concrete base edge outside the deficient area so that there shall be no additional joints.

350.09 MEASUREMENT FOR PAYMENT

350.09.01 Actual Measurement

350.09.01.01 Concrete Pavement

Subsection 350.09.01.01 is amended by the addition of the following:

If the concrete curb and gutter is poured monolithically (as part of the road slab), width measurements will be taken from back of curb to back of curb minus two times the width of the specified type curb and gutter. The curb and gutter will be measured in accordance with OPSS 353.09.01.01.

350.10 BASIS OF PAYMENT

350.10.01 Concrete Pavement - Item

Subsection 350.10.01 is deleted in its entirety and replaced by the following:

Payment at the contract price for the above items shall be full compensation for all labor, equipment and material required to do the work.

350.10.01.01 Compressive Strength and Slab Thickness

Subsection 350.10.01.01 is deleted in its entirety.

**OPSS.MUNI 351 CONSTRUCTION SPECIFICATION FOR CONCRETE
SIDEWALK****351.05 MATERIALS****351.05.06 Tactile Walking Surface Indicator Plates**

Subsection 351.05.06 is amended by the addition of the following:

Tactile walking surface indicators shall be according to CSA B651-2012.

Tactile walking surface indicators shall have ribs cast to the underside of the unit, have vent holes, and have a minimum plate thickness of 5 mm. The truncated domes shall be of uniform size and shape.

351.07 CONSTRUCTION**351.07.02.02 Granular Base**

Subsection 351.07.02.02 is amended by the addition of the following:

Granular Base for concrete sidewalks shall be Granular A and shall be a minimum thickness of 150 mm, unless otherwise specified in the Contract Documents.

351.07.06 Utility Adjustment

Paragraph 2 of Subsection 351.07.06 is deleted and replaced with the following:

Appurtenances maintained and owned by utility companies other than the Owner shall either be adjusted by the utility company concerned or by the Contractor (with approval from the applicable utility company). All arrangements to adjust the utility appurtenance shall be approved by the Contract Administrator. The Contractor shall excavate to the edge of the appurtenance and indicate the required grade of the new sidewalk.

351.07.09 Tactile Walking Surface Indicator Plate Installation

Subsection 351.07.09 is amended by the addition of the following:

Tactile walking surface indicators shall be installed in the concrete sidewalk at the back of the concrete curb across the full width of the dropped portion of the pedestrian ramp.

Any wet concrete on the tactile walking surface indicator plate surface shall be removed.

All vent and lifting holes shall be filled with non-shrink concrete grout flush with the surface of the tactile walking surface indicator plate base.

100mm wide drainage slots shall be provided at the low point(s) of the tactile walking surface indicator plate(s). Finished tactile walking surface indicators shall be free of standing water.

351.07.11 Joints

351.07.11.04 Expansion Joints

Subsection 351.07.10.04 is amended by the addition of the following:

Expansion joints shall be placed every fifth dummy joint.

351.07.17 Tactile Walking Surface Tolerances

Paragraph 2 of Subsection 351.07.17 is deleted and replaced with the following:

Tactile walking surface indicator plates shall be set in the concrete so that the top of the truncated domes are flush with the surface of the adjacent concrete sidewalk to a tolerance of ± 3 mm.

Where tactile walking surface indicators plates are rejected, the entire pedestrian ramp shall be removed and replaced at the expense of the Contractor, as directed by the Contract Administrator.

351.10.02 Tactile Walking Surface Indicators for Concrete Sidewalk Ramps – Item

Subsection 351.10.02 is amended by the addition of the following:

When there is not a separate Tender item for Tactile Walking Surface Indicators, payment at the Contract price for Concrete Sidewalk shall include full compensation for all labour, equipment, and material to do the work of Tactile Walking Surface Indicators.

OPSS 353 CONSTRUCTION SPECIFICATION FOR CONCRETE CURB AND GUTTER SYSTEMS

353.07 CONSTRUCTION

353.07.02 Foundation and Backfill

Subsection 353.07.02 is amended by the addition of the following:

Concrete curb and gutter shall have a Granular A base with a minimum thickness of 150 mm, except where concrete curb and gutter is installed on new full depth granular road base, where the thickness may be reduced to 50mm.

OPSS.MUNI 501 CONSTRUCTION SPECIFICATION FOR COMPACTING**501.07 CONSTRUCTION****501.07.01 General**

Subsection 501.07.01 is amended by the addition of the following:

“Jetting” is not an approved method of compaction unless otherwise specified in the Contract Documents.

OPSS.MUNI 706 CONSTRUCTION SPECIFICATION FOR TRAFFIC CONTROL SIGNING**706.07 Construction****706.07.01.02 Existing Small Signs**

Subsection 706.07.01.02 is deleted in its entirety and replaced with the following:

Prior to commencement of construction, the Contractor must record the location and type of each sign within the limits of the construction. The Contractor is responsible for removal, storage and reinstallation of all signs within the construction zone including the cost of replacing missing signs as a result of construction or theft. The signs must be reinstalled conforming to the Ontario Traffic Manual, Highway Traffic Act and as directed by the Contract Administrator.

OPSS.MUNI 710 CONSTRUCTION SPECIFICATION FOR PAVEMENT MARKING**710.02 REFERENCES**

Subsection 710.02 is amended with the addition of the following:

Ontario Ministry of Transportation Publications

Ontario Traffic Manual (OTM) Book 11, Pavement, Hazard and Delineation Markings

710.04 DESIGN AND SUBMISSION

710.04.01 General

Subsection 710.04.01 is amended with the addition of the following:

At the request of the Contract Administrator, the Contractor shall supply and deliver a sample of the pavement marking material specified in the contract to a designated lab for testing.

710.05 MATERIALS

710.05.03 Thermoplastic Pavement Marking Materials

Subsection 710.05.03 is amended by the addition of the following:

Thermoplastic pavement marking shall also conform to the requirements of Lafrentz “System 300”.

710.05.04 Field Reacted Polymeric Pavement Marking Materials

Subsection 710.05.04 is amended by the addition of the following:

Field reacted polymeric pavement marking material shall also conform to the requirements of Lafrentz “System 400”.

710.05.05 Preformed Plastic Pavement Marking Tape

Subsection 710.05.05 is amended by the addition of the following:

Preformed plastic pavement marking tape shall also conform to the requirements of 3M Stamark Series “440, 5730 and 5731.”

710.07 CONSTRUCTION

710.07.03 Pavement Marking Obliterating

Subsection 710.07.03 is amended by the addition of the following:

Pavement markings shall be removed using approved abrasive blasting equipment and material in accordance with OPSS 128.

The depth of the removal shall be the minimum required to totally remove the existing pavement markings to a normal depth, typically averaging 3 mm. Pavement marking obliterating shall be carried out using a soft abrasive blast cleaning system at locations specified in the contract ensuring that the asphalt pavement is not damaged in any way and that no pavement markings remain visible upon completion.

710.07.07 Permanent Pavement Marking

Subsection 710.07.07 is amended by the addition of the following:

Permanent pavement markings shall be placed within 24 hours after the surface asphalt has been completed.

710.09 MEASUREMENT FOR PAYMENT

710.09.01 Actual Measurement

710.09.01.01 Pavement Marking

Subsection 710.09.01.01 is deleted in its entirety and replaced by the following:

Measurement for pavement markings is by the horizontal length in metres of the line excluding gaps. Width of the lines shall be as specified in the Contract Documents.

The unit of measurement for symbols to be obliterated is each.

OPSS.MUNI 510 CONSTRUCTION SPECIFICATION FOR REMOVAL

510.10 Basis of Payment

510.10.01 Removal of Item

Paragraph 2 of Subsection 510.10.01 is deleted and replaced with the following:

Imported granular backfill shall be included in the tender item for the removal specified in Contract Documents.

OPSS.MUNI 1010 MATERIAL SPECIFICATION FOR AGGREGATES – BASE, SUBBASE, SELECT SUBGRADE, AND BACKFILL MATERIAL

1010.05 Materials

1010.05.03.02 Granular B Type II

Subsection 1010.05.03.02 is amended with the addition of the following:

Where “Granular B with Type II gradation” is specified in the contract documents, the aggregate may be produced from naturally formed deposits of sand, gravel and cobbles, but must meet the gradation requirements for Granular “B” Type II.

SUPPLEMENTAL SPECIFICATIONS – ROADS

Part 2 SUPPLEMENTAL SPECIFICATIONS FOR ROADS

2.1 Painting Edge of Concrete Curb and Gutter Reveal

On all projects where the surface asphalt is not expected to be placed immediately following the placement of base asphalt, and the concrete curb reveal is exposed for more than forty eight (48) hours, the contractor shall at his expense be responsible for supplying, placing and maintaining fluorescent orange spray paint on the exposed edge of the curb reveal.

At a minimum, the contractor shall apply paint to the curb reveal within forty eight (48) hours after the base asphalt has been placed, prior to snow accumulation and again in the spring immediately after the snow has melted or as directed by the Contract Administrator.

Where top asphalt placement is delayed beyond the next paving season, the Contractor is required to continue maintaining the painting of the curb reveal and will be reimbursed at time and materials.

2.2 Asphalt Ramps

On all projects where the top asphalt is not expected to be placed within forty eight (48) hours of base asphalt, the Contractor shall supply, place and compact hot mix asphalt to provide asphalt ramps at all wheel chair ramps and intersecting side streets, and at all appurtenances in conjunction with the placement of base asphalt. The ramps shall not form part of the permanent asphalt pavement and shall be removed prior to continuing paving operations.

SUPPLEMENTAL SPECIFICATIONS – ROADS

Part 3 SUPPLEMENTAL STANDARD DRAWINGS FOR ROADS

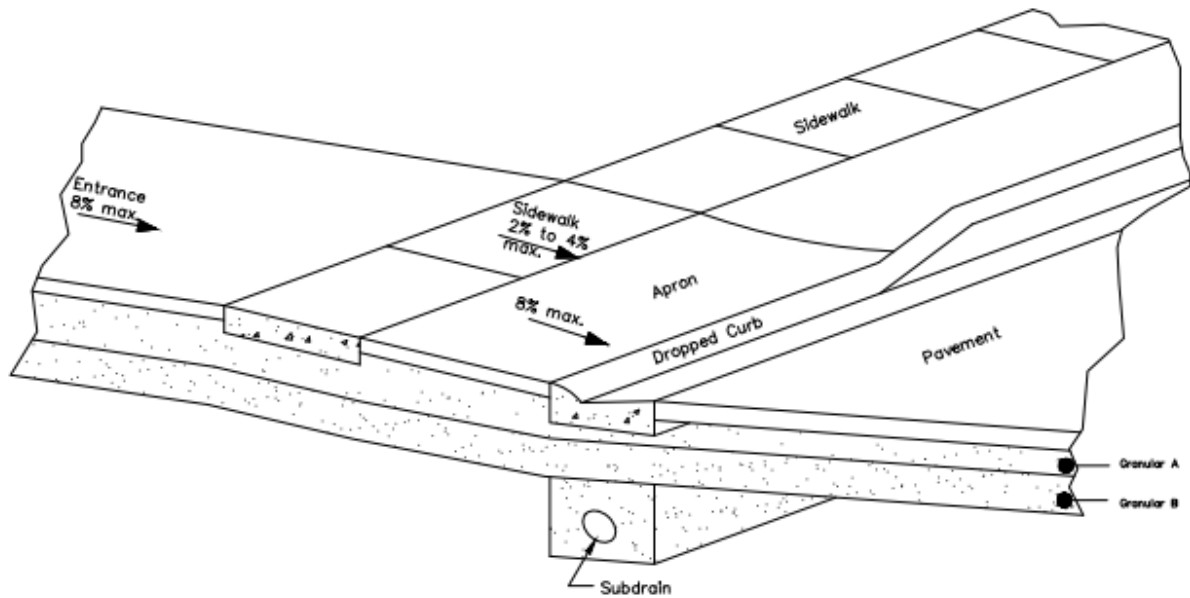

MINIMUM PAVEMENT STRUCTURE

RESIDENTIAL DRIVEWAYS:	
GRANULAR A	250mm
HL3 ASPHALT	75mm (TWO LIFTS)
INDUSTRIAL / COMMERCIAL / APARTMENT DRIVEWAYS:	
GRANULAR B	300mm
GRANULAR A	150mm
HL8 ASPHALT	50mm
HL3 ASPHALT	35mm

NOTES:

1. DRIVEWAYS & DRIVEWAY APRONS REPLACED DURING ROAD RECONSTRUCTION SHALL COMPRISE OF THE SAME DUST FREE MATERIALS AS THOSE PRESENT PRIOR TO THE INITIATION OF THE WORK TO THE MINIMUM OF THIS STANDARD WITH THE EXCEPTION OF STAMPED CONCRETE. STAMPED CONCRETE WILL BE REPLACED WITH PLAIN ONLY. WHERE EXISTING DRIVEWAY APRON IS GRAVEL, OR OTHER NON-DUST FREE SURFACE, THE DRIVEWAY APRON INCLUDING 1 m PAST BACK OF SIDEWALK SHALL BE REPLACED WITH ASPHALT.
2. ALL NEW DRIVEWAY APRONS ARE TO BE CONSTRUCTED TO THIS STANDARD.
3. PLAIN CONCRETE ONLY AT 150 mm (MIN) DEPTH MAY BE USED IN LIEU OF ASPHALT FOR RESIDENTIAL DRIVES. CONCRETE FOR COMMERCIAL/INDUSTRIAL/APARTMENT DRIVEWAYS SHALL BE 200mm (MIN) DEPTH.
4. RESIDENTIAL DRIVEWAYS SHALL CONFORM TO OPSD 351.010. MAXIMUM DRIVEWAY WIDTH SHALL NOT EXCEED 50% OF THE TOTAL LOT WIDTH.
5. INDUSTRIAL, COMMERCIAL, AND APARTMENT DRIVEWAYS SHALL CONFORM TO OPSD 350.010.

NOT TO SCALE
ALL DIMENSIONS IN MILLIMETERS UNLESS OTHERWISE NOTED

STANDARD DRAWING

**DRIVEWAY APRON
TYPICAL SECTION**

REVISION DATE: 26 NOV 2021
DRAWING #: **R-01**

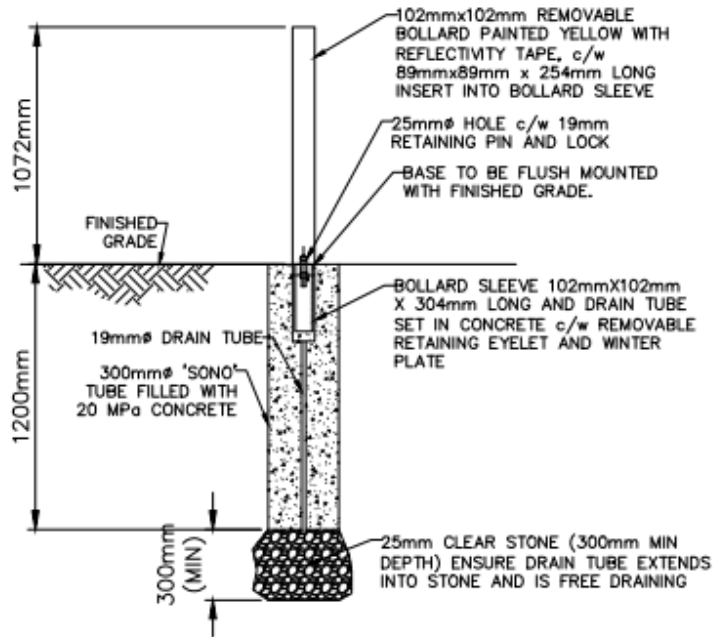

REMOVABLE BOLLARD DETAIL
COMPONENTS AS SUPPLIED BY RUCKUS FENCE

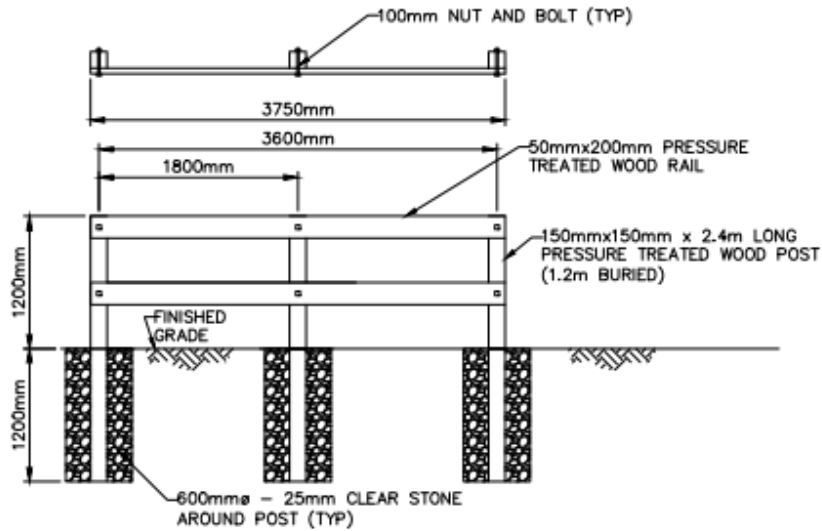

TRAIL HEAD FENCE DETAIL

NOT TO SCALE
ALL DIMENSIONS IN MILLIMETERS UNLESS OTHERWISE NOTED

STANDARD DRAWING

**REMOVABLE BOLLARD
& TRAIL HEAD DETAIL**

REVISION DATE: 26 NOV 2022
DRAWING #: **R-11**



SUPPLEMENTAL SPECIFICATIONS LANDSCAPING

SUPPLEMENTAL SPECIFICATIONS - LANDSCAPING

Part 1 AMENDMENTS TO ONTARIO PROVINCIAL STANDARDS FOR ROADS AND PUBLIC WORKS

OPSS.MUNI 801 CONSTRUCTION SPECIFICATION FOR THE PROTECTION OF TREES

801.03 DEFINITIONS

Subsection 801.03 is amended by the addition of the following:

Arborist means a person with a diploma or degree involving arboriculture from an accredited college or university, a registered professional forester, certified tree worker, an accredited certified arborist under the international society of arboriculture or with a demonstrated history of tree preservation experience or a registered consulting arborist with the American society of consulting arborists.

DBH means the diameter at breast height, measured on the stem 1.37 meters (4.5 feet) above the ground.

Destroy means to remove, cut down, or injure a tree in any way to such an extent that it has become a hazard or compromises its life processes in such a way that it cannot survive, and “Destruction” has a corresponding meaning.

Injury means any action causing harm, damage, or impairment, and includes, but is not limited to, the injury of trees by changing grades or compacting or excavating soils within the drip line of a tree, severing roots, the improper application of chemicals, improper pruning, attachments of any items, and the removal or slashing or defacing or girdling or burning of the bark.

Prune means the removal of a tree branch or branches from a tree.

Tree means any species of perennial woody plant that has reached or can reach a height of 4.5 meters at physiological maturity.

Tree Protection Zone (TPZ) means area within the minimum required distances in accordance with ISA Standards where no construction activity of any kind is permitted.

801.07 CONSTRUCTION

801.07.01 Operational Constraints

Subsection 801.07.01 is amended by the addition of the following:

A Tree Protection Zone (TPZ) barrier is to be constructed around all trees that are not subject to destruction within the construction area unless otherwise approved by the Contract Administrator.

Disposal of any liquids is not permitted within a TPZ.

Altering of grade by adding fill, excavating, trenching, scraping, dumping or disturbance of any kind is not permitted within a TPZ.

Directional micro-tunneling and boring may be permitted within the limits of the TPZ subject to approval by the Contract Administrator.

801.07.02 Barrier for Tree Protection

Paragraph 2 and Items a) and b) of Subsection 801.07.02 are deleted and replaced with the following:

The TPZ barriers shall be erected at the dripline of trees or woodlot edges not subject to destruction within the Working Area, prior to commencement of construction operations. Where a TPZ cannot be established at the dripline, the barrier may be placed within the dripline, subject to the approval of the Contract Administrator. When the barrier is placed within the dripline,

- a) a minimum distance of 1.2 m shall be maintained between the trunk of the tree and the TPZ barrier, and
- b) the TPZ shall be a minimum of 0.3 meters of diameter from the trunk for every 25 mm in DBH, or
- c) Where the tree is flanked by curb, sidewalk, roadway, etc. the barrier placement shall be to the furthest extent of the boulevard area, as approved by the Contract Administrator.

Should the location of the tree(s) limit or prevent the use of a barrier as identified above, the trunk of the tree shall be protected from mechanical damage by banding boards together to form a protective barrier immediately adjacent to the tree trunk. Such a barrier shall be self-supporting upon completion and installed with the approval of the Contract Administrator.

Subsection 801.07.02 is amended by the addition of the following:

The TPZ barrier shall be plywood or orange plastic snow fence or equivalent as approved by the Contract Administrator.

All TPZ barriers shall have signage affixed to the barrier at regular intervals clearly indicating "Tree Protection Zone."

801.07.03 Tree Repair

Subsection 801.07.03 is amended by the addition of the following:

All required tree trimming and root pruning must be completed by a qualified Arborist or approved tree care professional and in accordance with good arboricultural practices.

No root pruning closer than 300 mm for every 25 mm of trunk diameter will be permitted.

OPSS.MUNI 802 CONSTRUCTION SPECIFICATION FOR TOPSOIL

802.05 MATERIALS

Subsection 802.05.01 is amended by removing the physical properties comments and replacing them with the following:

Topsoil shall meet the following physical property requirements:

Description	Metric
pH	5.5 – 7.5
Organic Matter (%)	4 – 15
Total Salts (mmhos/cm)	< 1.5
Phosphorous (ppm)	10 – 60
Potassium (ppm)	80 – 250
Calcium (ppm)	1000 – 4000
Magnesium (ppm)	100 – 300
Chloride (ppm)	< 100
Sodium (ppm)	< 200
Sodium Adsorption Ratio	< 15
Sand Fraction %	20 – 75
Silt Fraction %	5 – 50
Clay Fraction (%)	5 - 10
Atrazine (ppm)	< 0.05 ppm

Topsoil will be tested every 500 sq.m. based on a depth of 100mm.

802.07 CONSTRUCTION

802.07.02 Preparation for Topsoil

Paragraph 1 of Subsection 802.07.02 is deleted and replaced with the following:

Areas where topsoil is to be placed shall be compacted to 95% Standard Proctor Maximum Dry Density and shall be fine graded to a uniform surface according to OPSS 206. The surface shall be loosened to a depth of 25 mm. It shall be free of all vegetation, debris, and stones which would not be covered by the depth of topsoil specified in the Placement of Topsoil subsection.

802.07.03 Placement of Topsoil

Subsection 802.07.03 is deleted in its entirety and replaced by the following:

Topsoil shall be spread to a uniform depth of 100 mm on areas specified in the Contract Documents or as directed by the Contract Administrator.

802.09 MEASUREMENT FOR PAYMENT

802.09.01.01 Topsoil from Stockpiles

Subsection 802.09.01.01 is deleted in its entirety and replaced by the following:

Where topsoil is to be placed and drawn from stockpiles built by the Contractor or from existing stockpiles designated in the Contract, measurement will be made in square metres of topsoil placed.

802.09.01.02 Topsoil, Imported

Subsection 802.09.01.02 is deleted in its entirety and replaced by the following:

Where topsoil is to be imported and placed, measurement will be made in square metres of topsoil placed.

OPSS.MUNI 803 CONSTRUCTION SPECIFICATION FOR SODDING

803.07 CONSTRUCTION

803.07.04 Placement of Sod

Subsection 803.07.04 is amended by the addition of the following:

Butt joints will be used where new sod blends with existing grass; lap joints will not be permitted.

803.07.05 Maintenance of Completed Sodding

Subsection 803.07.05 is deleted in its entirety and replaced by the following:

The Contractor shall apply maintenance watering and shall repair any break or displacement of sod, until 60 days after sod placement. At the end of the 60-day period, the sod shall be green and succulent, and show evidence of rooting into the underlying soil. Any area of sod which fails to meet these requirements shall be replaced by the Contractor, and shall be subject to a further extension of a sixty day maintenance period. The 60 day maintenance period shall exclude the winter dormant period, November 15 to April 15, inclusive.

803.08 QUALITY ASSURANCE

803.08.01 Performance Measure

Subsection 803.08.01 is deleted in its entirety and replaced by the following:

At the end of the 60 day maintenance period, an inspection of all the sod placed shall be made by the Contract Administrator. All placed sod shall be green and succulent, and show evidence of rooting into the underlying soil. All sod shall be in the same location as originally placed and shall not have moved, eroded, slipped or sloughed. Any areas which fail to meet these requirements shall be replaced by the Contractor at no cost to the Owner.

803.08.02 Acceptance

Paragraph 3 of Subsection 803.08.02 is deleted and replaced by the following:

Replaced sod shall be subject to the requirements specified herein and to a further maintenance period of 60 Days.

OPSS.MUNI 804 CONSTRUCTION SPECIFICATION FOR SEED AND COVER

804.05 MATERIALS

804.05.01 Seed

804.05.01.04 Permanent Seed Mixes

Subsection 804.05.01 is amended by the addition of the following:

Permanent Seed Mix shall be Standard Roadside Mix unless otherwise specified in the Contract Documents.

SUPPLEMENTAL SPECIFICATIONS – LANDSCAPING

Part 2 SUPPLEMENTAL SPECIFICATIONS FOR LANDSCAPING

2.1 Tree Removals

Tree removals shall be completed in accordance with the Contract Documents. All trees not marked for removal on the Contract Documents shall be protected from damage or injury in accordance with OPSS 801 as amended by the Supplemental Specifications.

All tree removals must be completed by a qualified Arborist or approved tree care professional and in accordance with good arboricultural practices.

2.2 Tree Planting

General

Tree planting shall be completed in accordance with the Contract Documents. Final locations of trees shall be approved by the Contract Administrator prior to planting.

The Contract Administrator shall be notified at least 48 hours prior to planting to allow for proper inspection of tree planting including the monitoring of the size of excavation, backfill, watering, compaction, tree and planting quality.

Materials

All street trees are to be of the type and species noted on the Contract Documents, and shall conform to C.N.T.A (Canadian Nursery Trades Association) standards, unless otherwise specified in the Contract Documents.

All street trees shall have a caliper of at least 50mm measured at 15cm above the root collar and at least two or three meters minimum height when planted, unless otherwise approved by the Contract Administrator.

All trees shall have a single stem, comparatively straight trunks, well developed leaders and branches, a well developed root system characteristic of the species, cultivar, or variety, and show evidence of proper nursery pruning.

All trees must be free of insects, disease, nutrient deficiencies, mechanical injury, or defect at the time of planting.

All tree roots must be balled and burlapped or contained within a wire basket.

Construction

Tree planting is to be undertaken after final grading and sodding has been completed.

Tree planting shall be completed in the recommended planting season for the tree species. The tree planting seasons for Southern Ontario is generally spring before the leaves begin to bud (mid April to the end of May), or autumn, after the leaves have fallen (mid September to the end of October).

Pits dug for planting of balled and burlapped or wire basket trees shall be a minimum of sixty centimeters (60cm) larger than the root ball to allow for proper backfilling of the tree. Soil in the bottom of the planting pit shall be undisturbed, or firmly tamped to support the root ball and reduce settling.

Trees shall be planted so that the root flare is level with the finished grade of the surrounding soil. Where heavy clay exists, trees are to be planted so that the root flare is two to five centimeters higher than the surrounding soil.

All wire and burlap is to be cut and removed from the base of the trunk and the top 2/3 of the root ball. These items are to be removed after the tree has been placed in the hole.

Backfill shall be native topsoil excavated from the tree pit, compacted to support a free standing tree, or imported loam topsoil mixture with similar properties to the surrounding soil.

When planting is completed, the entire area shall be saturated with water.

Fertilizer is not required at the time of planting.

Pruning practices following transplanting shall consist of the removal of dead, broken or injured branches; the removal of crossing or rubbing branches, uneven growth and water sprouts. Trees with no leader or which have been “headed-back”, or where branches have been excessively tipped back to meet height requirements will not be approved. All required tree trimming must be completed by a qualified Arborist in accordance with good arboricultural practices.

All trees shall be staked according to accepted arboriculture practices. Trees shall be double staked with either Bamboo poles or 50mm x 50mm (2”x 2”) wooden stakes, inserted outside the root ball. Tie the top of the stakes to prevent trunk from hitting the top of the stakes. Stakes are to be located opposite each other, parallel to the road or in the direction of the prevailing winds when the location is exposed to strong winds.

Guy attachments shall be biodegradable, non-abrasive ties or approved alternative. All guy supports shall be placed opposing each other, fastened in a manner so they will not girdle or abrade the tree, endanger public safety, and allow for some movement.

All trees shall be mulched with 100 mm of composted wood chips, shredded bark or similar organic mulch. Mulch area should include the root ball diameter plus one foot. The Contractor shall ensure mulch is not mounded around tree trunk, and all turf in mulched area is removed to the base of the tree.

All trees shall have an approved tree guard placed around the base of the tree of either a 6 inch Big O or ArborGard+ or approved equivalent.

Prior to the final acceptance the Contractor shall remove all stakes, ties, and tree guards.

Maintenance

The Contractor shall maintain the tree, mulch and stakes for the duration of the maintenance period

All maintenance practices shall follow ISA arboriculture practices and standards.

The Contractor shall thoroughly water all trees at time of planting and for the duration of the maintenance period, whenever there has been seven to ten days without rain, during the spring/summer season(s), to ensure good soil root contact and thereafter to maintain a healthy life.

All trees replaced during the maintenance period shall be guaranteed for one year from the date of the replacement planting.

Measurement and Payment

Payment for Trees shall be full compensation for all labor, equipment and materials required to carry out the work.

Payment shall be based on the actual number of trees planted.

2.3 Tree and Shrub Relocation

All required tree or shrub relocations must be completed by a qualified Arborist or qualified nursery professional and in accordance with good arboricultural practices.

Final locations of trees and shrubs shall be approved by the Contract Administrator.

Payment for Tree or Shrub Relocation shall be full compensation for all labor, equipment and materials required to carry out the work.

Payment shall be based on the actual number of trees or shrubs relocated.

2.4 Penalty for Tree Damage

A minimum \$500 penalty per incident will be deducted for trees unnecessarily injured during construction by the Contractor or their sub-contractors as determined by the Contract Administrator. If the injury to the tree is determined by the Contractor Administrator to threaten the survival of the tree and requires removal, the contractor shall pay all costs associated with the removal of the damaged tree, in addition to the penalty in accordance with the following schedule. The Contract Administrator may deduct any and all penalties due under this paragraph from any monies that may be due or payable to the Contractor.

Penalty Schedule for Tree Damage

	Diameter at breast height	Additional Penalty
Infraction		
Tree damaged by Constructor or Sub-Contractor	Under 10cm	\$ 500
	10cm > 35cm	\$ 1,000
	36cm > 60cm	\$ 1,500
	61cm > 100cm	\$ 2,500
	Larger than 100cm	\$ 3,500
Failure to maintain or remove tree protection zone barrier (without permission of Contract Administrator)	To be deducted per incident, in addition to any other penalties associated with tree damage	\$ 250

SUPPLEMENTAL SPECIFICATIONS – LANDSCAPING

Part 3 SUPPLEMENTAL STANDARD DRAWINGS FOR LANDSCAPING

NOTES

1. THIS DETAIL DOES NOT REPRESENT ANY PARTICULAR SPECIES
2. TREES MUST BE AT LEAST 50mm UNLESS OTHERWISE APPROVED BY THE PARKS AND RECREATION DEPARTMENT
3. WILL NOT ACCEPT TREES WITH MORE THAN 1 LEADER. NO CENTRAL LEADER. TREES SHOWING SIGNS OF STRESS, NUTRIENT DEFICIENCIES, MECHANICAL INJURY, OR TREES THAT HAVE BEEN EXCESSIVELY PRUNED TO MEET HEIGHT/SIZE REQUIREMENTS
4. IF TREES HAVE A CENTRAL LEADER THAT HAS A DEFINED LEAN, DIRECT AWAY FROM ANY OVERHEAD OBSTRUCTIONS
5. CROWN THIN ONLY WHERE BRANCHES ARE DEAD, BROKEN, RUBBING, OR HAVE A TIGHT 'V' SHAPED BRANCH UNION
6. DO NOT PRUNE THE CENTRAL LEADER
7. ANY TREES PLANTED TOO DEEP OR TOO HIGH SHALL BE IMMEDIATELY RE-ADJUSTED.
8. TREES SHALL BE THOROUGHLY WATERED AT THE TIME OF PLANTING .
9. BACKFILL SHALL BE THE SOIL THAT WAS EXCAVATED FROM THE TREE PIT, COMPACTED ENOUGH TO SUPPORT A FREE STANDING TREE, BE FREE OF AIR POCKETS, AND OF A LOAM TOPSOIL MIXTURE EQUIVALENT TO THE ISA STANDARDS IF EXCESS SOIL IS REQUIRED
10. STAKES SHALL BE BAMBOO POLES OR 50mm X 50mm WOODEN STAKES, INSERTED OUTSIDE THE ROOT BALL AND LOCATED OPPOSITE EACH OTHER PARALLEL TO THE ROAD OR IN THE DIRECTION OF THE PREVAILING WIND WHEN LOCATION IS EXPOSED TO STRONG WINDS
11. TIES SHALL BE BIODEGRADABLE, NON-ABRASIVE, PLACED OPPOSING EACH OTHER, AND ALLOW FOR SOME MOVEMENT
12. TREE GUARD (NOT SHOWN) SHALL EITHER BE BIG O OR ARBORGARD+, UNLESS OTHERWISE APPROVED BY THE PARKS AND RECREATION DEPARTMENT.
13. FERTILIZING IS NOT PERMITTED
14. PLANTING HOLE SHALL BE A MINIMUM OF 60CM LARGER THAN THE ROOT BALL, AND DEEP ENOUGH SO THE ROOT FLARE IS LEVEL WITH THE FINAL GRADE.
15. BASE OF THE PLANTING HOLE SHALL BE UNDISTURBED OR FIRMLY TAMPED ENOUGH TO NOT ALLOW THE ROOT BALL TO SETTLE
16. CUT AND REMOVE ALL WIRE, BURLAP, AND TWINE FROM AROUND THE BASE OF THE TRUNK, AND THE TOP 2/3 OF THE ROOT BALL. REMOVE THESE ITEMS AFTER THE TREE HAS BEEN PLACED IN THE HOLE
17. ROOT FLARE SHALL BE LEVEL WITH THE FINAL GRADE OF THE SURROUNDING SOIL, WHERE CLAY EXISTS PLANT 2-5 CENTIMETERS HIGH
18. MULCH SHALL BE 100mm DEEP AND SHOULD CONSIST OF COMPOSTED WOOD CHIPS OR ORGANIC MATERIAL, AT A DIAMETER TO BE THE SIZE OF ROOT BALL PLUS 0.3m.
19. KEEP MULCH 25 mm TO 50 mm AWAY FROM THE BASE OF TREE
20. DRAINAGE SHALL COMPLY WITH ROAD SPECIFICATIONS

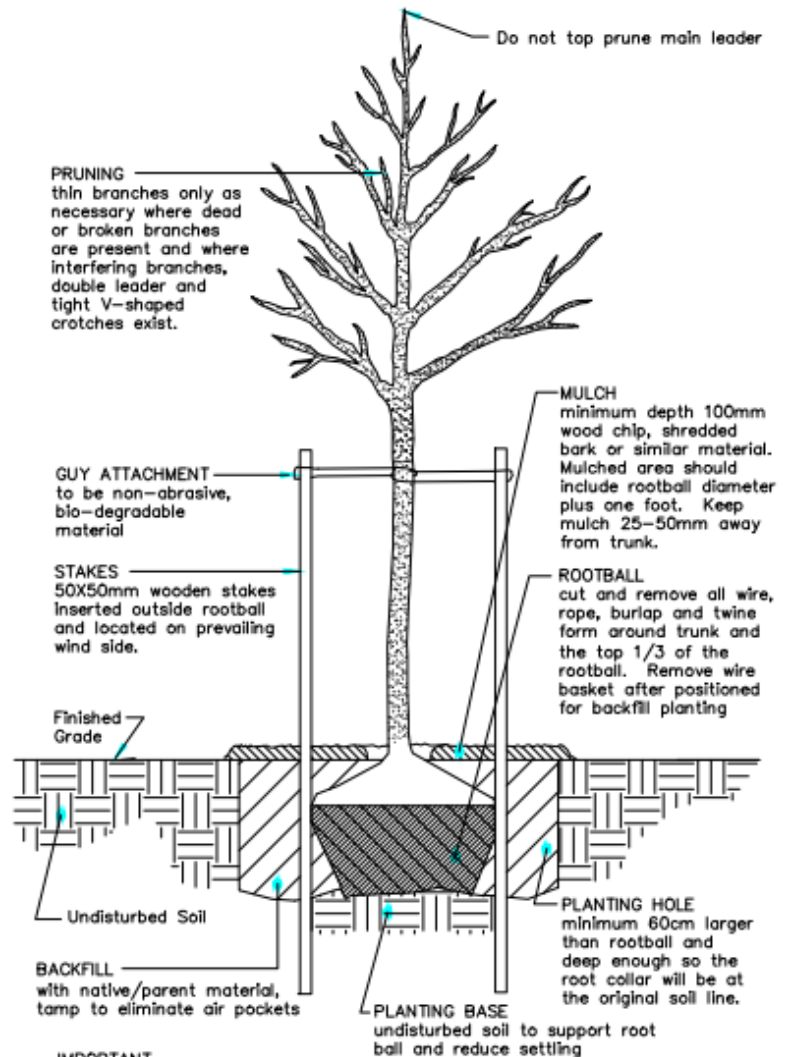

IMPORTANT

1. Remove all grass and weeds from base of tree.
2. Tree to be thoroughly watered immediately following planting.
3. Ensure mulch begins 15-20mm from tree trunk, do not mound mulch or soil around tree trunk.
4. Remove all nursery tabs, plastic, cardboard, or metal.

DECIDUOUS STREET TREE PLANTING

NOT TO SCALE
ALL DIMENSIONS IN MILLIMETERS UNLESS OTHERWISE NOTED

STANDARD DRAWING

**TREE PLANTING
DETAIL**

REVISION DATE: 26 NOV 2021
DRAWING #: **L-01**



SUPPLEMENTAL SPECIFICATIONS TRAFFIC SIGNALS

SUPPLEMENTAL SPECIFICATIONS – TRAFFIC SIGNALS

Part 1 AMENDMENTS TO ONTARIO PROVINCIAL STANDARDS FOR ROADS AND PUBLIC WORKS

OPSS.MUNI 106 GENERAL SPECIFICATION FOR ELECTRICAL WORK

106.04 Design and Submission Requirements

Subsection 106.04 of OPSS.MUNI 106 is amended to include the following:

106.04.01 Submission Requirements

106.04.01.01 Electrical Equipment Working Drawings

The Contractor shall submit one digital copy of Shop Drawings to the Contract Administrator for review. Shop Drawings are required for the following equipment:

- a) Poles
- b) Anchor Assemblies
- c) Luminaires
- d) Electrical Handholes
- e) Power Supply Assemblies
- f) Signal Heads for Traffic, Bicycle and Pedestrian – LED Modules, Push Buttons, & Push Button Housings

106.05 Materials

Subsection 106.05 of OPSS.MUNI 106 is amended to include the following:

Unless otherwise specified in the Contract or by the Contract Administrator, all traffic signal components for installation shall be new, fabricated and to meet the requirements of the Operating Authority. All materials, components or custom equipment shall be CSA approved, where applicable, and comply with the requirements of the Electrical Safety Authority with respect to their application.

All materials shall be stored in accordance with manufacturers' instructions to prevent damage, soiling, or finish spoilage. New poles shall be stacked to prevent bending or warping and shall be protected against any condition that may cause chipping or pitting in the finish.

The Contractor shall supply all materials as specified in the Form of Tender and any miscellaneous hardware and material (electrical tape, connectors, etc.) required for each installation.

106.07.01.02 Contractor's Workers

Subsection 106.07.01.02 of OPSS.MUNI 106 is amended by deleting the first paragraph and replacing it with the following:

For electrical work, the Contractor or Subcontractor shall have a licensed master electrician on staff, and shall use workers qualified to do work in accordance with OPSS 106 and the following:

- a) All electrical work shall be performed under the supervision of a licensed (Construction and Maintenance 309A) electrician.
- b) Personnel certified under "The Apprenticeship and Tradesman's Qualification Act" shall perform all electrical work. All personnel performing electrical work shall always carry proof of their certification under the Act on their person while on the work site.
- c) Electrical work at a traffic signal equipment installation shall be performed by a licensed electrician who has successfully completed the IMSA Level I and II, Traffic Signal Technician Certification Program.
- d) Electrical work at a traffic signal control equipment installation shall be performed by a licensed electrician who has successfully completed the IMSA Level I and II, Traffic Signal Technician Certification Program and having a minimum of five years previous experience in the assembly and maintenance of microprocessor-based traffic controllers.
- e) Electrical work at Street Lighting Equipment Installations shall be performed by a licensed electrician who has completed the IMSA Level 1 Roadway Certification Program.
- f) Personnel shall have related experience in the overall fields of traffic signal and/or street lighting installations.
- g) A qualified representative must be present and on-site whenever work is being carried out under the Contract.

106.07.02 Work to be Inspected by Electrical Safety Authority

Subsection 106.07.02 of OPSS.MUNI 106 is amended to include the following:

Upon completion of all work, the Contractor shall obtain a final certificate of approval from ESA and shall furnish one copy of the certificate to the Owner.

106.07.04 Traffic Signal Systems

106.07.04.03 Traffic Signal Systems Activation

Subsection 106.07.04.03 of OPSS.MUNI 106 is amended to include the following:

- d) The Contractor shall complete all preliminary system testing as indicated in the Contract and Inspect all items listed in PART 3 TRAFFIC SIGNAL ACTIVATION CHECK LIST
- e) The Contractor shall complete all bonding and grounding systems prior to signal activation
- f) The Contractor shall, at their expense, arrange for a police officer to be on site during signal testing energizing or de-energizing.
- g) The Contractor shall complete noted deficiencies within two weeks of receiving deficiency list.

106.07.04.04 Traffic Signal Systems Switchover

Subsection 106.07.04.04 of OPSS.MUNI 106 is amended to include the following:

The Contractor shall, at their expense, arrange for a police officer to be on site during signal testing energizing or de-energizing.

106.07.04.05 Maintenance of Traffic Signal Systems

106.07.04.05.01 General

Subsection 106.07.04.05.01 of OPSS.MUNI 106 is amended to include the following:

The Contract Administrator must be present when the Contractor energizes the traffic signals for full operation.

The Contractor shall have a qualified electrician present when energizing or de-energizing a traffic signal installation.

106.07.06 Temporary Electrical Work

Subsection 106.07.06 of OPSS.MUNI 106 is amended to include the following:

Existing roadway lighting systems, traffic signals systems and other traffic signal communication systems shall remain in operation until new or temporary systems are fully operational.

At all times during construction the light levels on roadway and sidewalk shall meet or exceed the existing pre-construction roadway and sidewalk lighting levels. Traffic management plan shall take into consideration lighting levels for all stages of construction.

106.07.07 Layout of Electrical Equipment

Subsection 106.07.07 of OPSS.MUNI 106 is amended to include the following:

Layout to be reviewed and confirmed in the field by the Contract Administrator prior to construction. The Contract Administrator, at their option, may revise the locations of equipment as required by field conditions, prior to installation.

106.07.08 Adjustment of Electrical Equipment

Subsection 106.07.08 of OPSS.MUNI 106 is deleted and replaced by the following:

The Contractor shall adjust all traffic signal heads, optical lens assemblies, luminaries, photoelectric controllers and other devices, which may be adjusted to give optimum performance. All equipment shall be installed in a neat and orderly manner to the satisfaction of the Contract Administrator.

Minor adjustments to equipment, which in the opinion of the Contract Administrator are required to improve the appearance of the site, shall be carried out at the Contractor's expense.

The Contractor shall adjust in luminaires during nighttime conditions, and if so required, to any equipment that can be adjusted to provide optimum performance. All such adjustments shall be carried out to the satisfaction of the Contract Administrator at the Contractor's expense.

For the adjustment of signal heads the contractor shall give the Contract Administrator a minimum of 3 working days notice prior to adjusting signal heads.

106.07.10 Quality Control

106.07.10.01 General

Subsection 106.07.10.01 of OPSS.MUNI 106 is amended to include the following:

Tests on electrical wiring and material shall, unless otherwise specified, conform to the Canadian Electrical Code Part 1 and Ontario Electrical Safety Code.

Testing shall be performed by qualified personnel only and shall be done in the presence of the Contract Administrator or an Electrical Safety Authority Inspector.

The Contractor shall provide all necessary instruments, equipment and personnel required to satisfactorily carry out prescribed tests at their own expense.

The following tests shall be performed as directed by the Contract Administrator:

- a) All conduits and duct systems shall be proven free of stones, dirt, water or other debris by pulling a test mandrel 6mm smaller in diameter than the nominal conduit or duct size through each individual conduit or duct.
- b) All circuits shall be proven continuous and free of short circuits or ground faults.
- c) All circuits shall be proven operable. Each control or switching device shall be operated no less than five (5) times and each circuit no less than eight (8) hours.
- d) The resistance to ground for all grounded equipment shall be proven to not exceed ten (10) ohms.

In addition to the above tests, the Contractor shall, where directed by the Contract Administrator, perform any tests called for where performance of the electrical system indicates a deficiency.

The Contract Administrator shall provide for tests on materials other than electrical measurements. The Contractor shall repair or replace the faulty equipment at their own expense, and to the satisfaction of the Contract Administrator.

All installations shall be made in a workmanlike manner to the satisfaction of the Contract Administrator.

The Contractor shall take all necessary measurements in the field in order to enable them to completely dimension all Contract Drawings. The Contractor shall demonstrate that the materials supplied meet the standards set forth in the specifications. The Contractor at their expense shall correct all defects.

The Contractor shall provide an unconditional warranty on the work done by the Contractor for a period of one year from the date of acceptance by the Operating Authority.

OPSS.MUNI 602 CONSTRUCTION SPECIFICATION FOR INSTALLATIONS OF ELECTRICAL CHAMBERS

602.07.11.02 Electrical Handholes

Subsection 602.07.13 of OPSS.MUNI 602 is amended by deleting the first paragraph and replacing it with the following:

Electrical Handholes shall be polymer concrete S1730B18FA complete with polymer ring and bolt down cover and shall be as manufactured by Synertech Moulded Products Inc. or approved alternate. Cover bolts shall be stainless steel hex head.

Electrical Handholes for detector loops shall be S1118SB12FA complete with polymer ring and bolt down cover and shall be as manufactured by Synertech Moulded Products Inc. or approved alternate. Cover bolts shall be stainless steel hex head.

All boxes shall be minimum ANSI/SCTE Tier 15 load rate.

All electrical handholes shall have service identification cast/engraved into the lid (i.e. "Streetlighting", "Traffic Signals").

602.07.13 Design and Submission Requirements

Subsection 602.07.13 of OPSS.MUNI 602 is amended to include the following:

Where a ground rod or plate is required in or adjacent to the maintenance / handhole or prefabricated service box, the system #6 AWG copper ground wire shall exit out of the maintenance / handhole or prefabricated service box to enable ground rod connection as indicated in the Contract.

OPSS.MUNI 603 CONSTRUCTION SPECIFICATION FOR INSTALLATIONS OF DUCTS

603.05.08 Ducts and Fittings

Subsection 603.05.08 of OPSS.MUNI 603 is amended to include the following:

The following minimum size conduit shall be installed in the following areas, unless otherwise specified on the Contract Drawings:

- a) Road Crossings – Handhole to handhole - 3/75 mm
- b) Boulevard – Handhole to Controller Pad - 4/75 mm + 1/50 mm
- c) Boulevard – Handhole to Pole Footing - 2/75 mm
- d) Boulevard – Handhole/Controller Pad to Power Supply - 2/50 mm
- e) Boulevard – Controller Pad to Communication Pedestal - 50 mm
- f) Boulevard – Handhole to Light Standard or Flasher - 50 mm
- g) Boulevard – Handhole to Junction Box for Loop Lead-in - 50 mm
- h) Boulevard – Junction Box to Curb Line/Edge of Pavement for Loop Lead-in - 50 mm

The type and number of conduit shall be laid out and constructed as shown in the Contract Drawings.

Open Cut Installation

Rigid ducts installed by open cut, direct buried, concrete encased and subsurface installation shall be rigid polyvinyl chloride (RPVC) (Scepter or approved alternate) conforming to CSA Standards C22.2 No. 211.2, except where otherwise indicated. At no time shall thin walled conduit be used.

Directional Boring

Rigid ducts installed by directional boring shall be rigid polyvinyl chloride (RPVC) unplasticized conduit conforming to CSA Standards C22.2 No. 211.2 except as otherwise indicated.

Boring shall be as per O.P.S.D. No. 2103.02. Specification for boring pit shall be as per O.P.S.D. No. 2103.06. Voids in borehole shall be pressure grouted.

603.07.15 Termination

Subsection 603.07.15 of OPSS.MUNI 603 is amended include the following:

Duct's to be sealed shall be sealed using Polywater FST Foam Duct Sealant or approved equivalent.

Ducts shall be sealed to a depth of no more than 100mm from termination point.

603.07.16 Backfilling

Subsection 603.07.16 of OPSS.MUNI 603 is amended to include the following:

The bore pits in boulevards areas when the method of directional boring is used shall be backfilled with granular material. Granular material shall be compacted to 100% Standard Proctor Maximum Dry Density and earth to 95% Maximum Dry Density. All grassed areas in boulevards will be reinstated with a minimum of 150mm topsoil and sod or seed as required under the Contract.

The bore pits in roadway surface areas when the method of directional boring is used shall be backfilled to the requirements of:

- a) OPSS.MUNI 1010, for Granular "A" and Granular "B" Type II and compacted to 100% Standard Proctor Maximum Dry Density. Granular "B" Type II backfill shall be used up to the elevation where Granular "A" is shown on the typical sections or elsewhere on the Contract Drawings. Granular "A" shall be used in the upper section as trench backfill.
- b) Utilizing unshrinkable backfill material.

603.10.16 Basis of Payment

603.10.01 Flexible Ducts Rigid Ducts, Concrete Encased Rigid Duct Direct Buried Rigid Ducts by Subsurface Installation

Subsection 603.10.01 of OPSS.MUNI 603 is amended to include the following:

No additional payment will be made for bends, risers, etc., unless specifically indicated.

Payment for conduit shall be per meter of conduit placed and shall include the supply and installation of the conduit, fish line, all bends, risers, caps, couplings, end bells, concrete, excavation of trenches, removal and disposal of materials, bedding, backfill and compaction.

OPSS.MUNI 609 CONSTRUCTION SPECIFICATION FOR GROUNDING

609.07 Construction

609.07.01 General

Subsection 609.07.01 of OPSS.MUNI 609 is extended to include the following:

The grounding cable shall form a continuous loop between the signal pole ground rods. Grounding of the poles shall be accomplished by cable run between the specified pole and the "loop". This shall safeguard the integrity of the grounding loop even if one or more poles are removed from the system. An insulated #6 AWG copper green coloured cable shall be interconnected between the ground loop and the service cabinet ground bus.

All signal poles shall be grounded by means of a six (6) gauge TWU cable (green).

The four (4) ground rods (minimum) for signal pole grounding shall be located adjacent to the junction boxes as indicated on the Contract Drawing.

The power cut-out box shall be grounded with two ground rods by means of one (1) six (6) gauge TWU cable (green) running from the box to an approved ground rod adjacent to the power supply.

The Contractor shall provide grounding for the traffic controller by means of installing an #6AWG insulated copper ground wire from the controller cabinet neutral bus bar to the service breaker ground bus.

These grounding cables shall exit the controller base (base mount cabinet) via a separate conduit stub-out provided for the sole use of this cable. The cable shall then be direct buried to service point.

OPSS.MUNI 610 CONSTRUCTION SPECIFICATION FOR REMOVAL OF ELECTRICAL EQUIPMENT AND MATERIALS

610.07 Construction

610.07.09 Salvage of Equipment

610.07.09.03 Shipping of Salvaged of Equipment

Subsection 610.07.09.03 of OPSS.MUNI 610 is amended to include the following:

The Contractor shall disassemble the following signal hardware and return components to a location specified by the Owners:

- existing control cabinet and all its contents
- all above ground detection system/equipment (i.e. cameras, radar etc.)
- all LED luminaires
- antennas or DSRC
- any pre-emption equipment (optical or GPS)

All other equipment is to be scrapped and the receipt value credited to the Owner. (i.e. Traffic Signal Heads, Pedestrian Heads, Poles, Arms, etc.). Unless specified otherwise in the Contract Documents or by the Contract Administrator.

Where salvaged equipment is required for re-use under the Contract, the Contractor shall be responsible for a clean and safe storage facility; the equipment shall be stored as per the manufacturer's requirements to avoid damage prior to re-installation.

The Contractor shall remove and dispose of all traffic signal and street lighting conductors from existing conduits.

All pole bases and handholes are to be removed in their entirety and disposed of.

The Contractor shall remove all temporary traffic signal equipment within the project limits after the completion and energizing of the permanent signals.

OPSS.MUNI 614 CONSTRUCTION SPECIFICATION FOR INSTALLATION OF POWER SUPPLY EQUIPMENT

614.05 Materials

Section 614.05 Materials of OPSS.MUNI 614 is amended by the addition of the following:

614.05.09 Meter Base

When required, the Contractor shall supply and install a socket type, 100 amp meter base, as per local hydro authority requirements, complete with top entry hub.

614.05.10 Power Supply Cabinet Assembly

The Contractor shall supply and install a pedestal enclosure Type SLM42, 100 Amp, 1Ø, 3 wire, supply control pedestal assembly complete with concrete base.

Pedestal shall have a load centre complete with circuit breakers.

Approved Manufactures:

- Pedestal Solutions Inc. & Brooklin Concrete or Utilicon for concrete Base, or approved equivalent.

EXAMPLE OF TYPICAL POWER SUPPLY CABINET ASSEMBLY “Type 1”

	Unit	Description
Supply 'A'	Each	Supply Control Cabinet Assembly, 120/240 Volt, 100 Amp, 1 Phase, 3 Wire complete with: 1-100 Amp, 2P Main Circuit Breaker (Factory installed) 1-50 Amp, Traffic Signal Circuit Breaker 2-30 Amp, 1P Circuit Breakers (Lighting) 4-30 Amp, 1P Circuit Breakers (Spare) 1-Secondary Surge Arrester, 650Vac phase to ground – Square D, Catalogue #QO2175SB 100A Meter Socket as per St. Thomas Energy Standards

614.05.11 Supply Control Cabinet Assembly

Control Cabinet to be supplied by the Owner.

614.07 Construction

614.07.04 Service Supply Pedestal

Section 614.05 Materials of OPSS.MUNI 614 is amended by the addition of the following:

The Contractor shall supply and install equipment for the power supply at the service pole as per Local Hydro requirements. The Contractor shall leave sufficient wire coiled at the transformer for the service connection to the secondary supply at the transformer.

Circuit breakers shall be installed as shown in the Contract and in accordance with the Operating Authority Standard Drawings. The Contractor shall install three (3) copper stranded RWU 90 conductors (Black, Red & White) from the hydro supply point to the load centre, leaving a sufficient length of cable coiled for connection to the hydro feed. Each conductor must be one continuous piece, with no splices.

The Contractor shall contact the respective Local Hydro representative two (2) weeks before power to the service is required and request a "Service Layout". The Contractor will meet the service representative on the site and explain what is required to complete the service. The Contractor is responsible for the cost of the Electrical Safety Authority inspection and power hookup by Local Hydro.

The installation of the power supply equipment and the power connections must be completed early in the Contract to ensure there is no delay to the traffic signal and illumination turn on. Therefore, the Contractor must have early communication with Local Hydro to ensure that the requirements (i.e., permits and inspection) have been satisfied and the earliest power connection can be made. The Contractor will arrange approval by the Electrical Safety Authority prior to Local Hydro being able to connect power feed.

OPSS.MUNI 615 CONSTRUCTION SPECIFICATION FOR ERECTION OF POLES

615.05 Materials

615.05.03 Poles

Subsection 615.05.03 of OPSS.MUNI 615 is deleted and replaced by the following:

All installed poles shall be Aluminum for base mounting and shall be according to OPSS 2452 unless specified otherwise in the Contract Documents.

The following base mounted, aluminum poles are approved for installation:

- a) 1.5m (5') – Light Duty, Traffic Signal
- b) 3.6m (12') – Light Duty, Traffic Signal
- c) 4.5m (15') – Light Duty, Traffic Signal
- d) 5.8m (19') – Heavy Duty, Traffic Signal
- e) 5.8m (19') – Light Duty, Traffic Signal
- f) 9.8m (32') – Heavy Duty, Traffic Signal, Streetlight Combination
- g) 9.8m (32') – Light Duty, Traffic Signal or Single Arm Streetlight
- h) 9.8m (32') – Light Duty, Double Arm Streetlight (6.3mm thick wall)

OPSS.MUNI 616 CONSTRUCTION SPECIFICATION FOR FOOTINGS AND PADS FOR ELECTRICAL EQUIPMENT

616.08 Quality Assurance

Subsection 616.08 of OPSS.MUNI 616 is amended by the addition of the following:

The Contract Administrator will inspect each pole footing. A maximum tolerance of 15 mm will be allowed from the top elevation of the footing to the adjacent grades or Contract Detail information.

OPSS.MUNI 620 CONSTRUCTION SPECIFICATION FOR TRAFFIC SIGNAL EQUIPMENT AND ELECTRICAL TRAFFIC CONTROL DEVICES

620.02 Definitions

Subsection 620.02 of OPSS.MUNI 620 is amended by the addition of the following:

Pedestrian Countdown Signal Head:

Traffic signal head comprising of changing numeric LED symbols.

620.07 Construction

620.07.02 Traffic Signals

620.07.02.04 Signal Heads

Subsection 620.07.02.04 of OPSS.MUNI 620 is amended by the addition of the following:

Signal heads shall be installed facing the direction of approaching traffic according to the “legal drawing” Form PHM-125, approved for the intersection.

The signal heads shall be securely covered with a durable coated nylon signal head bag and shall remain in place until all tests have been completed and the signal heads are put into operation. Pedestrian heads shall be turned to face the pole prior to operation.

Traffic signal head bags shall be a durable nylon bag with nylon straps and shock cords designed for traffic signal heads. All bags shall be equipped with a nylon mesh window for signal testing.

Signal heads shall be adjusted for maximum visibility and focusing prior to final tightening or sealing of hardware. Unused hubs in signal heads shall be plugged with sealing caps, without a gasket.

620.07.02.07 Wiring

Subsection 620.07.02.07 of OPSS.MUNI 620 is amended by the addition of the following:

Drip loops shall be left on all external cable to prevent ingress of water.

620.07.05.07 Pedestrian Push Buttons

Subsection 620.07.05.07 of OPSS.MUNI 620 is amended by the addition of the following:

Pedestrian pushbuttons at traffic signals shall be Polara 2 wire Navigator complete with CCU Board and all associated hardware required to suit the pole application outlined in the contract.

620.07.06 Traffic Signal Pre-Emption Equipment

Subsection 620.07.06 of OPSS.MUNI 620 is deleted and replaced with the following:

Emergency vehicle pre-emption equipment for the permanent installation shall consist of emergency pre-emption detector unit, connectors, discriminator modules, and aiming of the detector units as follows:

- Discriminator modules shall be GTT 760 Series
- Supply and install two GTT 722 optical detectors, complete with all mounting hardware for mast arm mounting as indicated in contract.

- Make all required wiring connections at Opticom detector and at controller cabinet. (Opticom detector cabling is paid for under “Traffic Signal Cables, in Rigid Duct” item in this contract)
- Any and all appurtenances required for proper installation.

The supply and installation of the optical detectors, wiring and all associated hardware will be carried out by the Contractor. The Contractor will complete all required wiring connections at the controller in accordance with manufacturer’s instructions and to the satisfaction of the Contract Administrator.

All Opticom cabling runs shall be continuous and shall be an unspliced length of cable.

The Contractor shall ground the optical detector heads.

Payment shall be by Plan Quantity and may be revised by Adjusted Plan Quantity. The unit of measurement is each.

620.07.08 Controller Supplied by Operating Authority, Installed by Contractor

Subsection 620.07.08 of OPSS.MUNI 620 is deleted and replaced with the following:

The Operating Authority will supply the controller prior to the scheduled inspection of the traffic signal installation by Electrical Safety Authority. The Operating Authority guarantees to the Contractor that the controller and all associated equipment are free of any defects.

The Contractor shall pick up the controller and transport it from the Operating Authority’s premises specified in the Contract. The Contractor must provide the operating authority at least 72 hours advance notice prior to picking up the unit. The Contractor shall ensure that all components are safely connected. Secured or packaged prior to transporting the controller. The Contractor shall transport the controller in an upright position, strapped and padded with bubble wrap.

The Contractor shall install the controller assembly and all associated equipment at the location shown on the Contract drawings.

OPSS.MUNI 2461 MATERIAL SPECIFICATION FOR SIGNAL HEADS**2461.05 Materials****2461.05.06 - Backboards**

Subsection 2461.05.06 of OPSS.MUNI 2461 is amended by deleting and replacing the first paragraph with the following:

Backboards shall be fabricated from minimum 1.00mm thick aluminum sheets and shall project a minimum 125mm all around beyond the signal head housing. The signal head backboard shall be yellow according to the Federal Specification Colour Yellow 59B-33538

Subsection 2461.05.06 of OPSS.MUNI 2461 is amended by deleting and replacing the third paragraph with the following:

The backboard shall be outfitted with a strip of 75 mm wide fluorescent yellow prismatic retroreflective sheeting according to ASTM D 4956, Type XI, around the front facing border (3M Diamond Grade DG³ Sheeting or approved equivalent).

SUPPLEMENTAL SPECIFICATIONS – TRAFFIC SIGNALS

Part 2 SUPPLEMENTAL SPECIFICATIONS FOR TRAFFIC SIGNALS

2.1 Traffic Signal Wiring

The Contractor shall supply and install one 19-conductor and one 7-conductor 14 gauge colour coded traffic signal cable per OPSS 2409 in each direction from the controller to accommodate all equipment and installation operations. The signal heads on each leg of the intersection shall be wired separately to the controller. This shall be done to allow addition of advanced greens or other split phases without additional wiring being required. The 19 conductor shall be utilized for vehicle signals and for pedestrian signals.

Pedestrian push button cable shall be 4 conductor, Belden #14 AWG shielded, or approved alternate.

“Lead in” cable for vehicle detector loop shall be 2 conductor, Belden #14AWG shielded, PVC jacketed, Canoga #300003 or approved alternate.

Loop cable shall be single conductor 7 strand copper No. 14 AWG type RWU90 with cross-link 400 black insulation.

Pre-emption detector cable shall be Opticom M138 detector cable.

All joints are to be made above ground level and inside the poles except in the case of any externally required connection which shall be housed in a weatherproof splice box. Underground splices will not be permitted except for loop lead-in cable.

The bid price for this item shall include all cable connections, waste cables, and all vertical runs of cable in conduit risers, from footings to pole handholes and to the inside of the controller cabinet.

All traffic signal, loop and communication cable used must meet the Operating Authority Specification. The installation of cables shall be carried out in the following manner and according to drawings:

- a) The Contract Administrator must approve materials used to facilitate the pulling of cables in conduit. Cable shall not be pulled at temperatures below -6 degrees C.
- b) Cable runs shall be continuous between poles. Signal cable splices shall only be made within a steel/aluminum pole handhole or junction boxes on a wooden pole. No signal cable splices are permitted below ground level.
- c) Sufficient length of free cable shall be left in pole handholes or junction boxes to permit proper connection to be made with cable coming from signal and/or pedestrian heads.

- d) Cable from signal and/or pedestrian heads on steel/aluminum poles shall run inside the mast arms and carry down inside the pole to the handhole.
- e) Cable from signal and/or pedestrian heads on wood poles shall run inside the mast arms and carry on up or down the outside of the pole to a 200 mm x 200 mm x 100 mm PVC watertight junction box. The junction box shall be mounted between 4 m and 5 m above the finished grade.
- e) Detector lead in cable from the vehicle detector loops shall be brought to the controller pad through the designated conduit and 1.5 m coiled up on the pad. These cables shall be one continuous piece with no splices and shall run from the curb side junction box to the controller pad.
- f) All signal cables shall terminate in the controller cabinet, as specified in the Contract, and be properly labelled as per PART 4 TRAFFIC CONTROLLER TAG LABELLING.

If, in the opinion of the Contract Administrator, any material used in the construction of any part of the cable is defective, or otherwise unsuitable, or if, in their opinion, the workmanship does not conform to accepted standards, the Contractor shall replace such defective cable at their own expense.

Any errors or omissions in, or misinterpretation of the specifications, or order shall not relieve the Contractor of the responsibility of providing cable conforming to modern practices and the best workmanship.

2.2 Mounting Equipment

Aluminum single member arms shall be the length specified in the contract documents. Mast arms shall be equipped with the appropriately sized pole mounting brackets to suit the applications shown on the contract drawing.

Traffic signal heads shall be mounted using dual end mounting traffic Signal Brackets.

Traffic signal mounting brackets shall be Astro-Brac model AB-0137 as supplied by Pelco Products Inc. or approved alternate.

Double arm brackets shall be constructed from 38 mm diameter Schedule 40 aluminum pipe and shall be complete with all associated aluminum fittings.

2.3 Maintenance of Traffic

The Contractor is responsible for the extra costs involved in keeping the road open to through traffic during construction, for the maintenance of the road, for maintaining access to businesses and residences for vehicles and pedestrians, and for carrying out other activities as specified and as required in connection with this specification.

The Contractor's traffic control and traffic maintenance shall be in accordance with the Ontario Traffic Manual – Book 7 (Construction and Maintenance) Traffic Control in Roadway Work Zones and shall adhere to the traffic control requirements under Ontario Regulation 213/91 s. 67-69.

Proper traffic control shall be maintained at all times during construction. The Contractor will be responsible for providing, maintaining and relocating where necessary, sufficient signs, delineators, barricades, lights, flashers, etc., and providing such traffic control persons and/or policemen as required so that motorists and pedestrians are properly directed to ensure safety.

Flagging procedures shall conform to the recommendations of Ontario Traffic Manual Book 7 – (Construction and Maintenance) Traffic Control in Roadway Work Zones and the Construction Safety Association of Ontario.

SUPPLEMENTAL SPECIFICATIONS – TRAFFIC SIGNALS

Part 3 TRAFFIC SIGNAL ACTIVATION CHECKLIST

TRAFFIC CABINET

- Gasket between extender base and concrete base pad
- Silicon sealant on the gasket between extender and base
- Silicon sealant between extender base and cabinet
- External silicone bead around both joints of extender base
- Cabinet free of major dents and scratches
- Ducts a sealed correctly

CABLES

- Power cables neatly formed and correct gauge
- Correct cable type used
- All signal, push button, detection and auxiliary cables neatly formed
- Phase conductors bent around terminal screw (stake-on type not permitted)

LABELLING

- All signal, push button, detection & Opticom cable labelled as per specification using one pieces tie wrap
- Style tag with permanent marker

CABINET MOUNTED EQUIPMENT

- Push button control modules correctly mounted on side panel brackets of controller cabinet
- Camera equipment correctly mounted

COMMUNICATIONS

- Communications cable present in access panel

SIGNAL HEADS

- Clean and no obvious damage
- Cowl visors
- Reflective tape
- Signal heads match design drawing
- Drip loop at end of mast arm
- Astrobrac cut flush with top of signal head
- Mounting height

MAST ARMS

- Correct length
- Drip loop (mast arm to pole)
- Grommet at pole cable entry
- Arms perpendicular to curb edge as shown on drawings
- Mast arm bracket to match pole cross section

POLES

- No major scratches or dents
- Aligned correctly with HH cover away from major traffic flow
- Leveling nuts underneath pole base
- Base nuts are tight (minimum one thread visible above base nuts)
- Hand hole cover present
- Pole cap installed
- Poles installed in correct position
- Base at correct grad
- Poles are aligned straight
- Sono tube cut flush with finished grad
- Stainless steel handhole cover bolts and stainless-steel bracket

PEDESTRIANS/COUNTDOWN HEADS

- Clean and no obvious damage
- Mounted straight
- Correct mounting height
- Drip loop in between double arm brackets
- Grommet at cable entry into pole
- Square LED modules

ELECTRIC HANDLES

- Installed on grade
- Level and present no trip hazard
- Drainage material in place
- Stainless-steel bolts
- Colour code ducts in handholes
- Engraved with correct usage (Streetlight, Traffic Signal)

LOOP DETECTION

- Central in lane
- Placed correctly
- Correct dimensions
- Correctly sealed in asphalt
- Silicone marrette style connector with grease filled kick-it 2 covers on loop tails

CAMERA DETECTION (IF APPLICABLE)

- Camera installed as per manufacturers specifications

GENERAL

- Curb ramps line up with sidewalk crossing pavement markings
- Curb ramps extend enough for unimpeded walk from button to crosswalk
- Sidewalk level with no trip hazard

PAVEMENT MARKINGS AND SIGANAGE

- Crosswalks lineup correctly with the ramps and buttons
- Stop bar lines present and in correct locations
- No conflicting temporary markings visible
- All lane markings at intersection as per design
- Stop here on red sign in correct location (where applicable)
- Signal ahead and new starburst signs in correct location (where applicable)

GROUND CIRCUIT AND BONDING

- Isolated #2/10 ground cable between service cabinet and grounding grid
- Isolated #6 ground cable between service cabinet and traffic control cabinet
- Isolated grounds to traffic controller must be identified with yellow tape where visible in junction boxes
- Compression style connection on all ground connectors
- #6 system ground to directly connected pole ground lug

STREET LIGHTING

- Fuse kits
- Correct cable type (rwu90 standard)
- Load side of streetlighting conductor to be crimped in fuse kit
- Bird stops
- All connection to be compression type taped with insulated cover
- Luminaires leveled
- Correct wattage and distribution
- Install wattage labels on luminaire

Part 4 TRAFFIC CONTROLLER TAG LABELLING

Labelling the traffic and pedestrian phases, and all detection inputs must satisfy the following:

1. Type of Cable: Cable Ty – Thomas and Betts TY153M (or approved equivalent)
2. Legibly printed with permanent marker
3. Located with the first 150mm below the associated phase or input terminal.

Examples of labelling below:

Traffic phase labelling



Advance traffic phase labelling



Pedestrian phase labelling



Push button input labelling



Opticom labelling



Loop detector labelling

